

**MALLA REDDY ENGINEERING COLLEGE
(AUTONOMOUS)**

Maisammaguda, Dhulapally (Post Via. Kompally), Secunderabad – 500100,
Telangana State, India



**DEPARTMENT OF
ELECTRICAL & ELECTRONICS ENGINEERING**

**Course Material
for
SWITCH GEAR AND PROTECTION**

**For
B.Tech (EEE)**

2017-18 Onwards (MR-17)	MALLA REDDY ENGINEERING COLLEGE (Autonomous)	B.Tech. VI Semester		
Code: 70217	SWITCHGEAR AND PROTECTION	L	T	P
Credits: 3		2	2	-

Prerequisites: DC Machines and Transformers, AC Machines, Power System Analysis, Power Generation and Distribution.

Course Objectives:

This course deals with different kinds of circuit breakers and relays for protection of generators, transformers and feeder bus bars from over voltages and other hazards. It also emphasis on Neutral grounding for overall protection.

MODULE I: Circuit Breakers 10 Periods

Circuit Breakers: Elementary principles of arc interruption, Recovery, Restriking Voltage and Recovery voltages - Restriking Phenomenon, Average and Max. RRRV, Numerical Problems - Current Chopping and Resistance Switching - CB ratings and Specifications-Construction and Operation of Minimum Oil Circuit breakers, Air Blast Circuit Breakers, Vacuum and SF6 circuit breakers-Numerical problems.

MODULE II: Relays 10 Periods

Principle of Operation and Construction of Attracted armature, Balanced Beam, induction Disc and Induction Cup relays. Relays Classification: Instantaneous, DMT and IDMT types.

Application of relays: Over current/ under voltage relays, Direction relays, Differential Relays and Percentage Differential Relays.

Universal torque equation, Distance relays: Impedance, Reactance and Mho and Off-Set Mho relays, Characteristics of Distance Relays and Comparison.

Static Relays: Static Relays versus Electromagnetic Relays.

MODULE III: System Protection 10 Periods

A: Protection of Generators: Stator fault protection, Rotor fault protection, Restricted Earth fault and Inter-turn fault Protection, Numerical Problems on % Winding Unprotected.

Protection of Transformers: Percentage Differential Protection, Numerical Problems on Design of CT Ratio, Buchholtz relay Protection.

B: Protection of Feeders: Over Current, Carrier Current and Three-zone distance relay protection using Impedance relay, Translay Relay.

Protection of Bus bars: Differential protection.

MODULE IV: Neutral Grounding 9 Periods

Grounded and Ungrounded Neutral Systems- Effects of Ungrounded Neutral on system performance. Methods of Neutral Grounding: Solid, Resistance, Reactance - Arcing Grounds and Grounding Practices.

MODULE V: Protection Against Over Voltages 9 Periods

Generation of Over Voltages in Power Systems.-Protection against Lightning Over Voltages - Valve type and Zinc-Oxide Lighting Arresters - Insulation Coordination -BIL, Impulse Ratio, Standard Impulse Test Wave, Volt-Time Characteristics.

TEXT BOOKS

1. Sunil S. Rao, “**Switchgear and Protection and Power System**”, 13th Edition, Khanna Publishers, New Delhi, 2008.
2. Soni, M.L., Gupta, P.V., Bhatnagar, U.S. and Chakrabarti, “**A Text Book on Power Systems Engineering**”, Dhanpat Rai & Sons Company Limited, New Delhi, 2nd Edition, 2003.

REFERENCES

1. Badari Ram, D.N Viswakarma, “**Power System Protection and Switchgear**” Tata McGraw Hill, 2nd Edition, 2010.
2. C.L.Wadhwa, “**Electrical Power Systems**”, New Age international (P) Limited, 4th edition, 2006.
3. Paithankar and S.R.Bhide , “**Fundamentals of Power System Protection**”, Prentice Hall of India, 2nd Edition 2003.
4. B. Ravindranath, and M. Chander, “**Power System Protection & Switchgear**”, 2nd Edition, New Age International, 2005.
5. S. L. Uppal, “**Electrical Power**”, 13th Edition, Khanna Publishers, New Delhi, 2006.

E – RESOURCES

1. <https://www.electrical4u.com/electrical-switchgear-protection/>
2. <http://www.electricity-today.com/>
3. <http://nptel.ac.in/downloads/108101039/>

Course Outcomes

At the end of the course, students will be able to

1. Analyze the operation of various types of circuit breakers.
2. Identify Characteristics of Relay for specific applications of protection
3. Design the feasible protection systems for generators, transformers, feeders and bus bars.
4. Emphasis on Grounding practices in real time.
5. Investigate the fundamentals of protection against over voltages.

LECTURE NOTES
ON
SWITCHGEAR PROTECTION

Contents

	Page no
Module-1:Circuit breakers	7-47
Introduction	7
Arc Phenomenon	8
Methods of Arc Extinction (or) Interruption	9
Expression for Restriking voltage and RRRV	14
Current chopping	18
Resistance Switching	20
Switchgear Components	23
Circuit Breaker Ratings	26
Oil Circuit Breakers	30
Air-Blast Circuit Breakers	39
Sulphur Hexafluoride (SF6) Circuit Breakers	42
Vacuum Circuit Breaker	45
Module -II:Electromagnetic and Static Relays	48-72
Introduction	48
Basic Relays	50
Electromagnetic Attraction Relays	50
Induction Relays	53
Shaded-Pole Structure	54
Watt-hour-Meter Or Double Winding Structure	54
Induction Cup Structure	55
Induction Type Directional Over current Relay	60
Current Differential Relay	61

Impedance Relay	63
Reactance Relay	66
Mho Relay	68
Offset mho Relay	70
Static Relays	72
Module -III:Protection of Alternators , Transformers, Busbars and feeders	73-98
Protection of Alternators	73
Merz-price Differential Protection	75
Biased Differential Protection for Alternators	76
Rotor Earth Fault Protection	77
Restricted Earth Fault Protection	79
Stator Inter-Turn Protection	80
Transformer Protection	81
Percentage differential protection	81
Buchholz Relay Protection	85
Protection of Busbars and Lines	87
Time-Graded Overcurrent Protection	90
Differential Pilot-Wire Protection	93
Distance Protection	96
Module -IV:Neutral Grounding	99-119
Grounding	99
Ungrounded Neutral System	104
Neutral Grounding	108
Solid or effective grounding	109
Resistance grounding	112
Reactance grounding	114
Peterson-coil grounding	114
Voltage Transformer Earthing	116
Grounding Transformer	117

Module -V: Protection Against Over Voltages 119-134

External over voltages	119
Internal over voltages	120
Protection against Lighting over voltages	121
Valve type Lightning arrester	123
Zinc-Oxide Lightening arrestor	126
Insulation Cooordination	130

CIRCUIT BREAKERS

Module - I

Introduction:

During the operation of power system, it is often desirable and necessary to switch on or off the various circuits (e.g., transmission lines, distributors, generating plants etc.) under both normal and abnormal conditions. In earlier days, this function used to be performed by a switch and a fuse placed in series with the circuit. However, such a means of control presents two disadvantages.

1. Firstly, when a fuse blows out, it takes quite sometime to replace it and restore supply to the customers.
2. Secondly, a fuse cannot successfully interrupt heavy fault currents that result from faults on modern high- voltage and large capacity circuits.



Due to these disadvantages, the use of switches and fuses is limited to low voltage and small capacity circuits where frequent operations are not expected e.g., for switching and protection of distribution transformers,

lighting circuits, branch circuits of distribution lines etc.



With the advancement of power system, the lines and other equipment operate at very high voltages and carry large currents. The arrangement of switches along with fuses cannot serve the desired function of switchgear

in such high capacity circuits. This necessitates employing a more dependable means of control such as is obtained by the use of **circuit breakers**.



A circuit breaker can make or break a circuit either manually or automatically under all conditions viz., no-load, full- load and short-circuit conditions.



This characteristic of the circuit breaker has made it very useful equipment for switching and protection of various parts of the power system.



A circuit breaker is a piece of equipment which can

(i) Make or break a circuit either manually or by remote control under normal conditions.

(ii) Break a circuit automatically under fault conditions

(iii) Make a circuit either manually or by remote control under fault conditions

Thus a circuit breaker incorporates manual (or remote control) as well as automatic control for switching functions. The latter control employs relays and operates only under fault conditions.

Operating principle:

A circuit breaker essentially consists of fixed and moving contacts, called Electrodes. Under normal operating conditions, these contacts remain closed and will not open automatically until and unless the system becomes faulty. Of course, the contacts can be opened manually or by remote control whenever desired. When a fault occurs on any part of the system, the trip coils of the circuit breaker get energized and the moving contacts are pulled apart by some mechanism, thus opening the circuit.

- When the contacts of a circuit breaker are separated under fault conditions, an arc is struck between them. The current is thus able to continue until the discharge ceases.
- The production of arc not only delays the current interruption process but it also generates enormous heat which may cause damage to the system or to the circuit breaker itself.
- Therefore, the main problem in a circuit breaker is to extinguish the arc within the shortest possible time so that heat generated by it may not reach a dangerous value.

Arc Phenomenon:

When a short circuit occurs, a heavy current flows through the contacts of the circuit breaker before they are opened by the protective system. At the instant when the contacts begin to separate, the contact area decreases rapidly and large fault current causes increased current density and hence rise in temperature. The heat produced in the medium between contacts (usually the medium is oil or air) is sufficient to ionize the air or vaporize and ionize the oil. The ionized air or vapor acts as conductor and an arc is struck between the contacts.

- The potential difference between the contacts is quite small and is just sufficient to maintain the arc.
- The arc provides a low resistance path and consequently the current in the circuit remains UN interrupted so long as the arc persists.
- During the arcing period, the current flowing between the contacts depends upon the arc resistance. The greater the arc resistance, the smaller the current that flows between the contacts.

The arc resistance depends upon the following factors:

1. **Degree of ionization**- the arc resistance increases with the decrease in the number of ionized particles between the contacts.

2. **Length of the arc**— the arc resistance increases with the length of the arc i.e., separation of contacts.
3. **Cross-section of arc**— the arc resistance increases with the decrease in area of X-section of the arc.

Principles of Arc Extinction:

Before discussing the methods of arc extinction, it is necessary to examine the factors responsible for the maintenance of arc between the contacts. These are:

1. Potential difference between the contacts.
2. Ionized particles between contacts taking these in turn.



When the contacts have a small separation, the Potential difference between them is sufficient to maintain the arc. One way to extinguish the arc is to separate the contacts to such a distance that Potential

difference becomes inadequate to maintain the arc. However, this method is impracticable in high voltage system where a separation of many meters may be required.



The ionized particles between the contacts tend to maintain the arc. If the arc path is demonized, the arc extinction will be facilitated. This may be achieved by cooling the arc or by bodily removing the ionized

particles from the space between the contacts.

Methods of Arc Extinction (or) Interruption:

There are two methods of extinguishing the arc in circuit breakers viz.

1. High resistance method.
2. Low resistance or current zero method

High resistance method:

In this method, arc resistance is made to increase with time so that current is reduced to a value insufficient to maintain the arc. Consequently, the current is interrupted or the arc is extinguished.



The principal disadvantage of this method is that enormous energy is dissipated in the arc. Therefore, it is employed only in D.C. circuit breakers and low-capacity a.c. circuit breakers.

The resistance of the arc may be increased by:

1. **Lengthening the arc:** The resistance of the arc is directly proportional to its length. The length of

the arc can be increased by increasing the gap between contacts.

2. **Cooling the arc:** Cooling helps in the deionization of the medium between the contacts. This increases the arc resistance. Efficient cooling may be obtained by a gas blast directed along the arc.
3. **Reducing X-section of the arc:** If the area of X-section of the arc is reduced, the voltage necessary to maintain the arc is increased. In other words, the resistance of the arc path is increased. The cross-section of the arc can be reduced by letting the arc pass through a narrow opening or by having smaller area of contacts.
4. **Splitting the arc:** The resistance of the arc can be increased by splitting the arc into a number of smaller arcs in series. Each one of these arcs experiences the effect of lengthening and cooling. The arc may be split by introducing some conducting plates between the contacts.

Low resistance or Current zero method:

In this method is employed for arc extinction in a.c. circuits only. In this method, arc resistance is kept low until current is zero where the arc extinguishes naturally and is prevented from restriking in spite of the rising voltage across the contacts. All Modern high power a.c. circuit breakers employ this method for arc extinction.

- In an a.c. system, current drops to zero after every half-cycle. At every current zero, the arc extinguishes for a brief moment.
- Now the medium between the contacts contains ions and electrons so that it has small dielectric strength and can be easily broken down by the rising contact voltage known as restriking voltage.
- If such a breakdown does occur, the arc will persist for another half cycle.
- If immediately after current zero, the dielectric strength of the medium between contacts is built up more rapidly than the voltage across the contacts, the arc fails to restrike and the current will be interrupted.

The rapid increase of dielectric strength of the medium near current zero can be achieved by:

- Causing the ionized particles in the space between contacts to recombine into neutral molecules.
- Sweeping the ionized particles away and replacing them by un ionized particles.

Therefore, the real problem in a.c. arc interruption is to rapidly de ionize the medium between contacts as soon as the current becomes zero so that the rising contact voltage or restriking voltage cannot breakdown the space between contacts.

The de-ionization of the medium can be achieved by:

1. **Lengthening of the gap:** The dielectric strength of the medium is proportional to the length of the gap between contacts. Therefore, by opening the contacts rapidly, higher dielectric strength of the medium can be achieved.
2. **High pressure:** If the pressure in the vicinity of the arc is increased, the density of the particles constituting the discharge also increases. The increased density of particles causes higher rate of de-ionization and consequently the dielectric strength of the medium between contacts is increased.
3. **Cooling:** Natural combination of ionized particles takes place more rapidly if they are allowed to cool. Therefore, dielectric strength of the medium between the contacts can be increased by cooling the arc.
4. **Blast effect:** If the ionized particles between the contacts are swept away and replaced by UN ionized particles, the dielectric strength of the medium can be increased considerably. This may be achieved by a gas blast directed along the discharge or by forcing oil into the contact space.

There are two theories to explain the Zero current interruption of the Arc:

1. Recovery rate theory (Slepain's Theory)
2. Energy balance theory (Cassie's Theory)

Recovery rate theory (Slepain's Theory):

The arc is a column of ionized gases. To extinguish the arc, the electrons and ions are to be removed from the gap immediately after the current reaches a natural zero. Ions and electrons can be removed either by recombining them in to neutral molecules or by sweeping them away by inserting insulating medium (gas or liquid) into the gap. The arc is interrupted if ions are removed from the gap recovers its dielectric strength is compared with the rate at which the restriking voltage (transient voltage) across the gap rises. If the dielectric strength increases more rapidly than the restriking voltage, the arc is extinguished. If the restriking voltage rises more rapidly than the dielectric strength, the ionization persists and breakdown of the gap occurs, resulting in an arc for another half cycle.

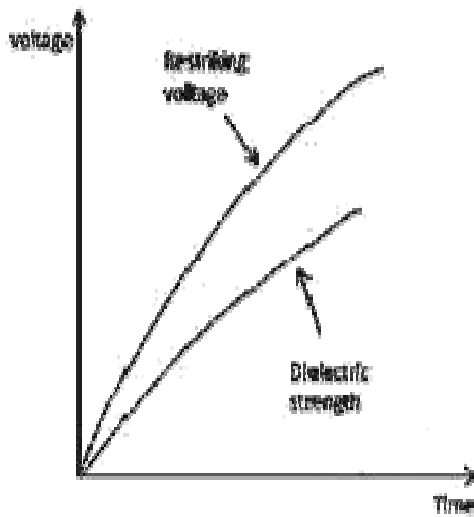

(a) Arc Extinguishes

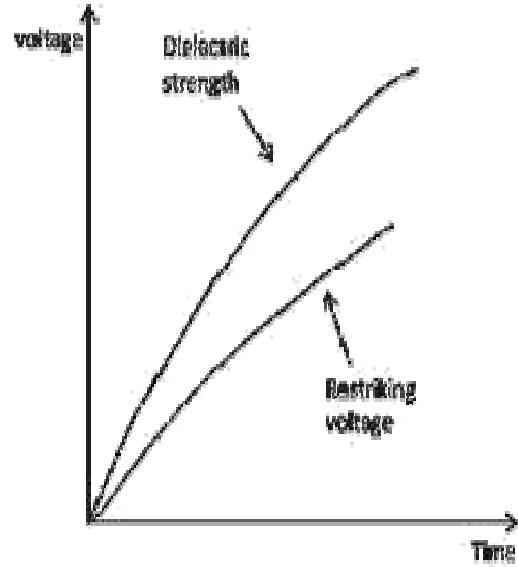

(b) Arc Persists

Energy balance theory (Cassie's Theory):

The space between the contacts contains some ionized gas immediately after current zero and hence, it has a finite post-zero moment, power is zero because restriking voltage is zero. When the arc is finally extinguished, the power gain becomes zero, the gap is fully de-ionized and its resistance is infinitely high. In between these two limits, first the power increases, reaches a maximum value, then decreases and finitely reaches zero value as shown in figure. Due to the rise of restriking voltage and associated current, energy is generated in the space between the contacts. The energy appears in the form of heat. The circuit breaker is designed to remove this generated heat as early as possible by cooling the gap, giving a blast air or flow of oil at high velocity and pressure. If the rate of removal of heat is faster than the rate of heat generation the arc is extinguished. If the rate of heat generation is more

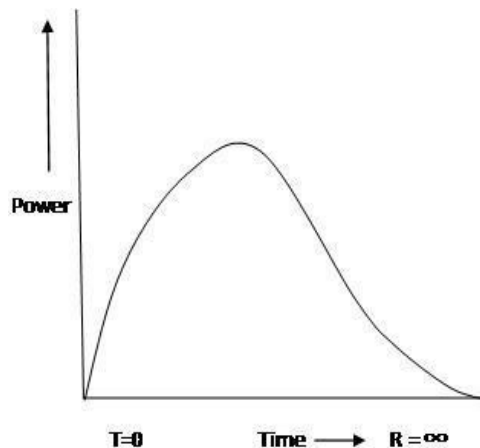

than the rate of heat dissipation, the space breaks down again resulting in an arc for another half cycle.

Important Terms:

The following are the important terms much used in the circuit breaker analysis:

1. Arc Voltage:

It is the voltage that appears across the contacts of the circuit breaker during the arcing period. As soon as the contacts of the circuit breaker separate, an arc is formed. The voltage that appears across the contacts during arcing period is called the arc voltage. Its value is low except for the period the fault current is at or near zero current point. At current zero, the arc voltage rises rapidly to peak value and this peak voltage tends to maintain the current flow in the form of arc.

2. Restriking voltage:

It is the transient voltage that appears across the contacts at or near current zero during arcing period. At current zero, a high-frequency transient voltage appears across the contacts and is caused by the rapid distribution of energy between the magnetic and electric fields associated with the plant and transmission lines of the system. This transient voltage is known as restriking voltage (Fig. 19.1).

The current interruption in the circuit depends upon this voltage. If the restriking voltage rises more rapidly than the dielectric strength of the medium between the contacts, the arc will persist for another half-cycle. On the other hand, if the dielectric strength of the medium builds up more rapidly than the restriking voltage, the arc fails to restrike and the current will be interrupted.

3. Recovery voltage:

It is the normal frequency (50 Hz) R.M.S. voltage that appears across the contacts of the circuit breaker after final arc extinction. It is approximately equal to the system voltage.

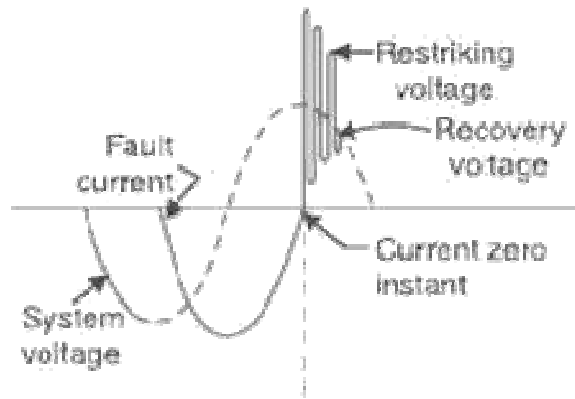

Fig. 19.1

When contacts of circuit breaker are opened, current drops to zero after every half cycle. At some current zero, the contacts are separated sufficiently apart and dielectric strength of the medium between the contacts attains a high value due to the removal of ionized particles. At such an instant, the medium between the contacts is strong enough to prevent the breakdown by the restriking voltage. Consequently, the final arc extinction takes place and circuit current is interrupted. Immediately after final current interruption, the voltage that appears across the contacts has a transient part (See Fig.19.1). However, these transient oscillations subside rapidly due to the damping effect of system resistance and normal circuit voltage appears across the contacts. The voltage across the contacts is of normal frequency and is known as recovery voltage.

Expression for Restriking voltage and RRRV:

The power system contains an appreciable amount of inductance and some capacitance. When a fault occurs, the energy stored in the system can be considerable. Interruption of fault current by a circuit breaker will result in most of the stored energy dissipated within the circuit breaker, the remainder being dissipated during oscillatory surges in the system. The oscillatory surges are undesirable and, therefore, the circuit breaker must be designed to dissipate as much of the stored energy as possible.

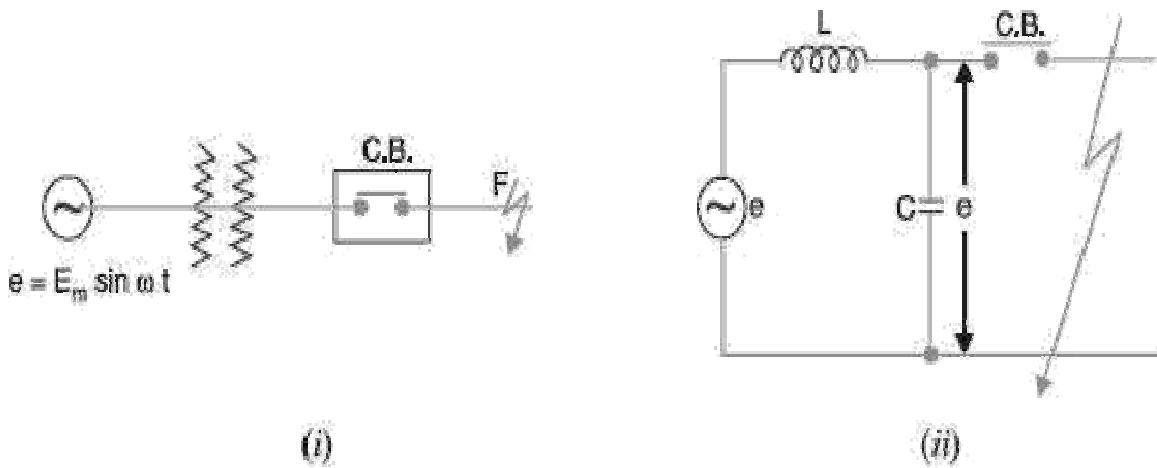

Fig. 19.17

Fig. 19.17 (i) shows a short-circuit occurring on the transmission line. Fig 19.17 (ii) shows its equivalent circuit where L is the inductance per phase of the system up to the point of fault and C is the capacitance per phase of the system. The resistance of the system is neglected as it is generally small.

Rate of rise of re-striking voltage:

It is the rate of increase of re-striking voltage and is abbreviated by R.R.R.V. usually; the voltage is in kV and time in microseconds so that R.R.R.V. is in kV/ μ sec.

Consider the opening of a circuit breaker under fault conditions Shown in simplified form in Fig. 19.17

(ii) above. Before current interruption, the capacitance C is short-circuited by the fault and the short-circuit current through the breaker is limited by Inductance L of the system only. Consequently, the short-circuit current will lag the voltage by 90° as shown in Fig. 19.18, where I Represents the short-circuit current and e_a represents the arc voltage. It may be seen that in this condition, the *entire generator voltage appears across inductance L .

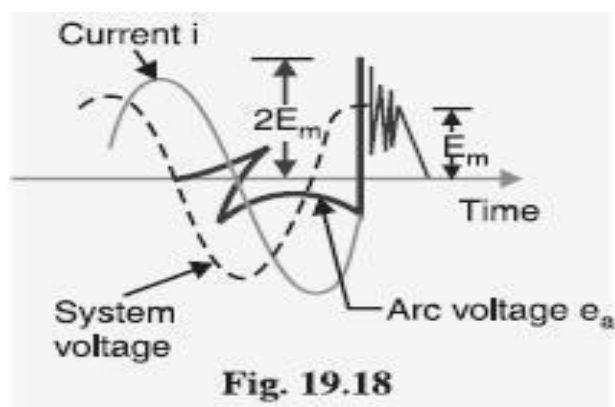

Fig. 19.18

When the contacts are opened and the arc finally extinguishes at some current zero, the generator voltage e is suddenly applied to the inductance and capacitance in series.

2π LC

This LC combination forms a series oscillatory circuit and voltage across capacitance which is restriking voltage rises and oscillates.

The natural frequency of oscillations is given by $f_n = 1/2\pi\sqrt{LC}$

The voltage across the capacitance which is the voltage across the contacts of the circuit breaker can be calculated in terms of L , C , f_n and system voltage. The mathematical expression for transient condition is as follows.

$$E = L \frac{di}{dt} + \frac{1}{C} \int i dt$$

$$i = dq/dt = d(CV_c)/dt$$

$$di/dt = d^2(CV_c)/dt^2 = Cd^2V_c/dt^2$$

$$E = LCd^2V_c/dt^2 + V_c$$

$$E/S = LCS^2V_c(S) + V_c(S)$$

$$E/S[LCS^2+1] = V_c(S)$$

$$V_c(S) = E/LCS[S^2+1/LC] = E\omega_n^2/S(S^2+\omega_n^2) \quad \text{where } \omega_n = 1/\sqrt{LC}$$

Taking inverse Laplace transform

$$V_c(t) = E(1 - \cos\omega_n t) = E(1 - \cos 1/\sqrt{LC} t) = \text{restriking voltage}$$

The maximum value of restriking voltage = $dv_c(t)/dt=0$

$$\underline{\quad} = 2E_{\text{peak}} = 2 \times \text{Peak value of system voltage}$$

The rate of rise of restriking voltage (RRRV)

$$= \omega_n E$$

$\sin\omega_n t$ The maximum value of RRRV = $\omega_n E =$

$\omega_n E_{\text{peak}}$

Which appears across the capacitor C and hence across the contacts of the circuit breaker. This transient voltage, as already noted, is known as re-striking voltage and may reach an instantaneous peak value twice the peak phase-neutral voltage i.e. $2 E_m$. The system losses cause the oscillations to decay fairly rapidly but the initial overshoot increases the possibility of re-striking the arc.

It is the rate of rise of re-striking voltage (R.R.R.V.) which decides whether the arc will re-strike or not. If

R.R.R.V. is greater than the rate of rise of dielectric strength between the contacts, the arc will re-strike. However, the arc will fail to re-strike if R.R.R.V. is less than the rate of increase of dielectric strength between the contacts of the breaker.

The value of R.R.R.V. depends up on:

1. Recovery voltage
2. Natural frequency of oscillations

For a short-circuit occurring near the power station bus-bars, C being small, the natural frequency f_n will be high. Consequently, R.R.R.V. will attain a large value. Thus the worst condition for a circuit breaker would be that when the fault takes place near the bus-bars.

Current chopping:

It is the phenomenon of current interruption before the natural current zero is reached. Current chopping mainly occurs in air-blast circuit breakers because they retain the same extinguishing power irrespective of the magnitude of the current to be interrupted. When breaking low currents (e.g., transformer magnetizing current) with such breakers, the powerful de-ionizing effect of air-blast causes the current to fall abruptly to zero well before the natural current zero is reached. This phenomenon is known as current chopping and results in the production of high voltage transient across the contacts of the circuit breaker as discussed below:

Consider again Fig. 19.17 (ii) repeated as Fig. 19.19 (i). Suppose the arc current is i when it is chopped down to zero value as shown by point a in Fig. 19.19 (ii). As the chop occurs at current i , therefore, the energy stored in inductance is $L i^2 / 2$.

The prospective voltage e is very high as compared to the dielectric strength gained by the gap so that the breaker restrike. As the de-ionizing force is still in action, therefore, chop occurs again but the arc current this time is smaller than the previous case. This induces a lower prospective voltage to re-ignite the arc. In fact, several chops may occur until a low enough current is interrupted which produces insufficient induced voltage to re-strike across the breaker gap. Consequently, the final interruption of current takes place.

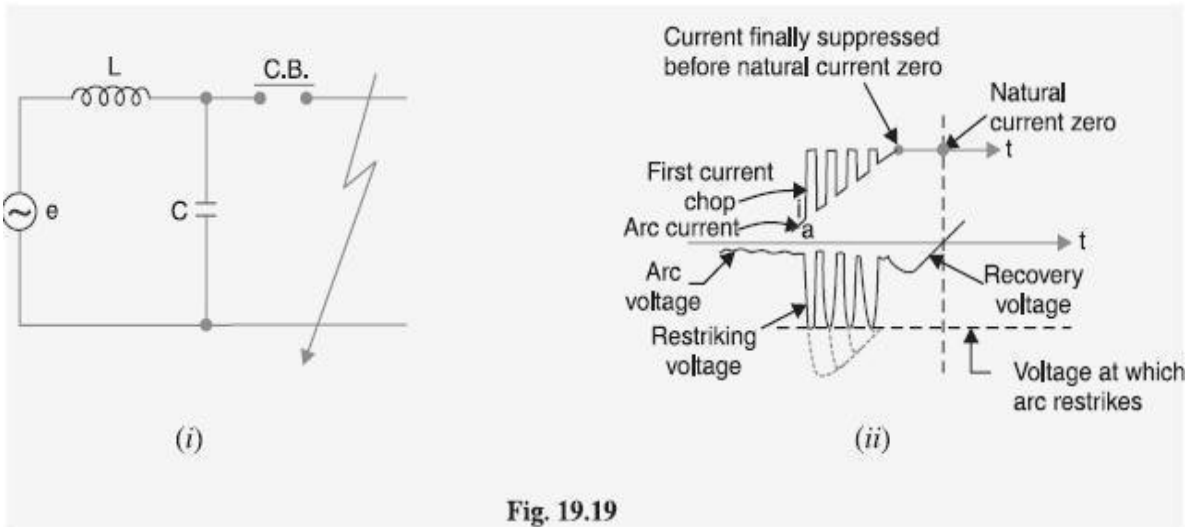

Fig. 19.19

Excessive voltage surges due to current chopping are prevented by shunting the contacts of the breaker with a resistor (resistance switching) such that re ignition is unlikely to occur. This is explained in Art 19.19.

Capacitive current breaking:

Another cause of excessive voltage surges in the circuit breakers is the interruption of capacitive currents. Examples of such instances are opening of an unloaded long transmission line, disconnecting a capacitor bank used for power factor improvement etc. Consider the simple equivalent circuit of an unloaded transmission line shown in Fig.19.20. Such a line, although unloaded in the normal sense, will actually carry a capacitive current I on account of appreciable amount of capacitance C between the line and the earth.

Let us suppose that the line is opened by the circuit breaker at the instant when line capacitive current is zero [point 1 in Fig. 19.21. At this instant, the generator voltage V_g will be maximum (i.e. V_{gm}) lagging behind the current by 90° . The opening of the line leaves a standing charge on it (i.e., end B of the line) and the capacitor C_1 is charged to V_{gm} . However, the generator end of the line (i.e., end A of the line) continues its normal sinusoidal variations. The voltage V_r across the circuit breaker will be the difference between the voltages on the respective sides. Its initial value is zero (point 1) and increases slowly in the beginning. But half a cycle later [point R in Fig. 19.21], the potential of the circuit breaker contact 'A' becomes maximum negative which causes the voltage across the breaker (V_r) to become $2 V_{gm}$. This voltage may be sufficient to restrike the arc. The two previously separated parts of the circuit will now be joined by an arc of very low resistance. The line capacitance discharges at once to reduce the voltage across the circuit breaker, thus setting up high frequency transient. The peak value of the initial transient will be twice the voltage at that instant i.e., $-4 V_{gm}$. This will cause the transmission voltage to swing to $-4V_{gm}$ to $+ V_{gm}$ i.e., $-3V_{gm}$.

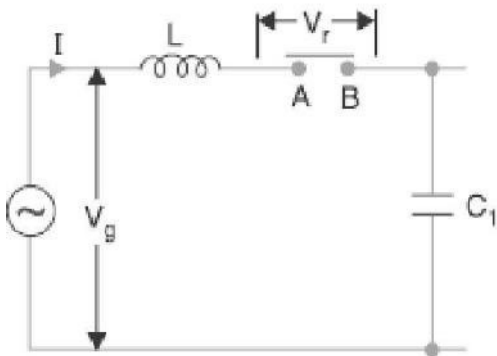

Fig. 19.20

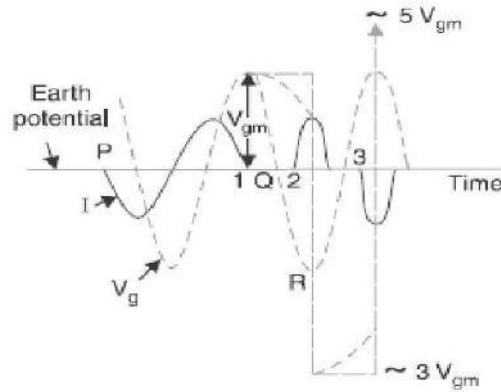

Fig. 19.21

The re-strike arc current quickly reaches its first zero as it varies at natural frequency. The voltage on the line is now $-3 V_{gm}$ and once again the two halves of the circuit are separated and the line is isolated at this potential. After about half a cycle further, the aforesaid events are repeated even on more formidable scale and the line may be left with a potential of $5 V_{gm}$ above earth potential. Theoretically, this phenomenon may proceed

infinitely increasing the voltage by successive increment of 2 times V_{gm} .

While the above description relates to the worst possible conditions, it is obvious that if the gap breakdown strength does not increase rapidly enough, successive re-strikes can build up a dangerous voltage in the open circuit line. However, due to leakage and corona loss, the maximum voltage on the line in such cases is limited to $5 V_{gm}$.

Resistance Switching:

It has been discussed above that current chopping, capacitive current breaking etc. give rise to severe voltage oscillations. These excessive voltage surges during circuit interruption can be prevented by the use of shunt resistance R connected across the circuit breaker contacts as shown in the equivalent circuit in Fig. 19.22. This is known as resistance switching.

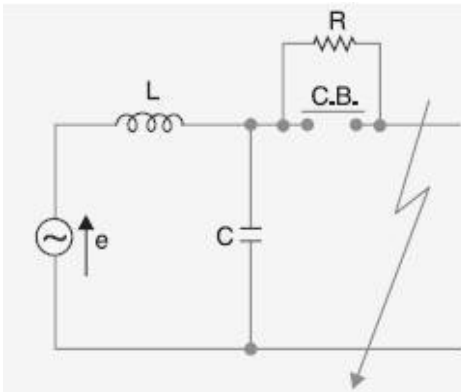

Fig. 19.22

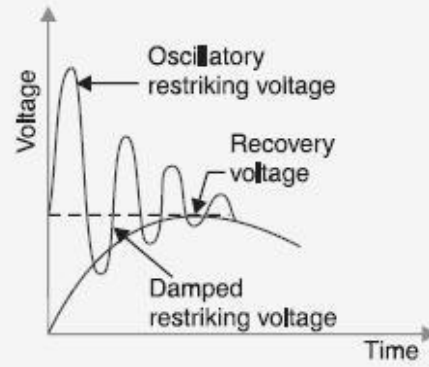

Fig. 19.23

Referring to Fig. 19.22, when a fault occurs, the contacts of the circuit breaker are opened and an arc is struck between the contacts. Since the contacts are shunted by resistance R , a part of arc current flows through this resistance. This results in the decrease of arc current and an increase in the rate of de-ionization of the arc path. Consequently, the arc resistance is increased. The increased arc resistance leads to a further increase in current through shunt resistance. This process continues until the arc current becomes so small that it fails to maintain the arc. Now, the arc is extinguished and circuit current is interrupted.

The voltage equation is given by

$$L \frac{di}{dt} + \frac{1}{C} \int i dt = E \quad \text{and} \quad i = i_c + i_R$$

Therefore, the above equation become

$$L \frac{d(i_c + i_R)}{dt} + v_c = E$$

or

$$L \frac{di_c}{dt} + L \frac{di_R}{dt} + v_c = E$$

$$i_c = \frac{dq}{dt} = \frac{d(Cv_c)}{dt}$$

Therefore,

$$\frac{di_c}{dt} = \frac{d^2(Cv_c)}{dt^2} = C \frac{d^2v_c}{dt^2}$$

$$\frac{di_R}{dt} = \frac{d(v_c/R)}{dt} = \frac{1}{R} \frac{dv_c}{dt}$$

Substituting these values in the main equation, we get

$$LC \frac{d^2v_c}{dt^2} + \frac{L}{R} \frac{dv_c}{dt} + v_c = E$$

Taking Laplace Transform, we get

$$LCS^2v_c(s) + \frac{L}{R} S v_c(s) + v_c(s) = \frac{E}{s}$$

Other terms are zero, as $v_c = 0$ at $t = 0$

$$\text{or} \quad LCv_c(s) \left[s^2 + \frac{1}{RC} s + \frac{1}{LC} \right] = \frac{E}{s}$$

$$\text{or} \quad v_c(s) = \frac{E}{sLC \left[s^2 + \frac{1}{RC} s + \frac{1}{LC} \right]}$$

For no transient oscillation, all the roots of the equation should be real. One root is zero, i.e. $s = 0$ which is real. For the other two roots to be real, the roots of the quadratic equation in the denominator should be real. For this, the following condition should be satisfied.

$$\left[\left(\frac{1}{2RC} \right)^2 - \frac{1}{LC} \right] \geq 0 \quad \text{or} \quad \frac{1}{4R^2C^2} \geq \frac{1}{LC}$$

$$\text{or} \quad \frac{4}{LC} \leq \frac{1}{R^2C^2} \quad \text{or} \quad R^2 \leq \frac{LC}{4C^2}$$

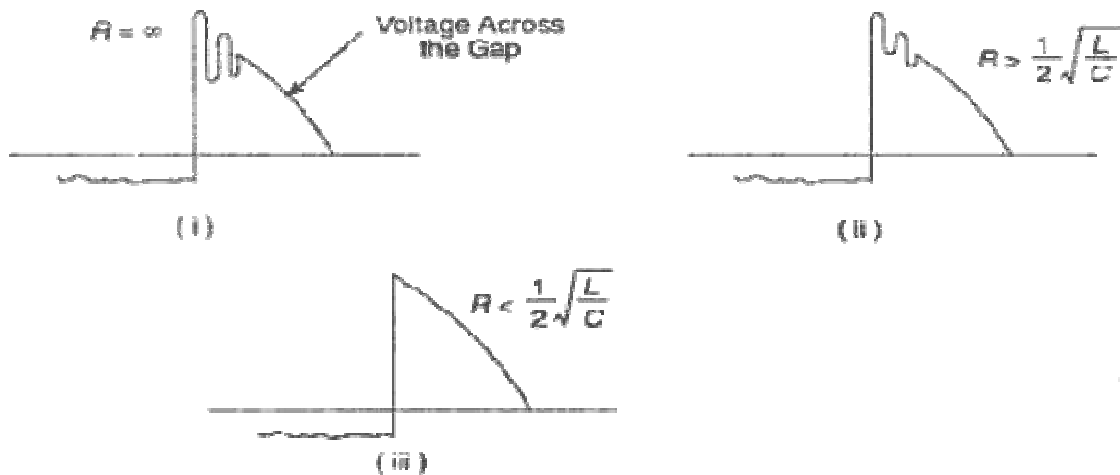

FIGURE 9.9 Transient oscillations for different values of R

or
$$R^2 \leq \frac{1}{4} \cdot \frac{L}{C} \quad \text{or} \quad R \leq \frac{1}{2} \sqrt{\frac{L}{C}}$$

Therefore, if the value of the resistance connected across the contacts of the circuit breaker is equal to or less than $\frac{1}{2}\sqrt{L/C}$ there will be no transient oscillation. If $R > \frac{1}{2}\sqrt{L/C}$, there will be oscillation. $R = \frac{1}{2}\sqrt{L/C}$ is known as critical resistance. Figure 9.9 shows the transient conditions for three different values of R .

The shunt resistor also helps in limiting the oscillatory growth of re-striking voltage. It can be proved mathematically that natural frequency of oscillations (or) the frequency of damped oscillation of the

$$f_n = \frac{1}{2\pi} \sqrt{\frac{1}{LC} - \frac{1}{4R^2C^2}}$$

circuit shown in Fig. 19.22 is given by:

The effect of shunt resistance R is to prevent the oscillatory growth of re-striking voltage and cause it to grow exponentially up to recovery voltage. This is being most effective when the value of R is so chosen that the circuit is critically damped. The value of R required for critical damping is $0.5 \sqrt{L/C}$. Fig. 19.23 shows the oscillatory growth and exponential growth when the circuit is critically damped.

To sum up, resistors across breaker contacts may be used to perform one or more of the following functions:

1. To reduce the rate of rise of re-striking voltage and the peak value of re-striking voltage.
2. To reduce the voltage surges due to current chopping and capacitive current breaking.
3. To ensure even sharing of re-striking voltage transient across the various breaks in multi break circuit breakers.

It may be noted that value of resistance required to perform each function is usually different. However, it

is often necessary to compromise and make one resistor do more than one of these functions.

Switchgear Components:

The following are some important components common to most of the circuit breakers:

1. Bushings
2. Circuit breaker contacts
3. Instrument transformers
4. Bus-bars and conductors

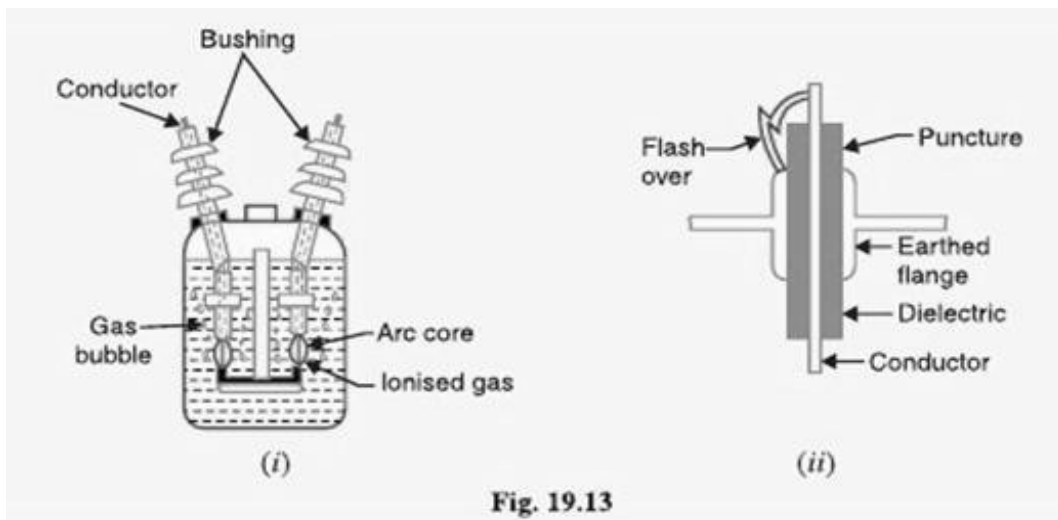

Fig. 19.13

Bushings:

When a high voltage conductor passes through a metal sheet or frame which is at earth potential, the necessary insulation is provided in the form of bushing. The primary function of the bushing is to prevent electrical breakdown between the enclosed conductor and the surrounding earthed metal work. Fig. 19.13 (i) shows the use of bushing for a plain-break oil circuit breaker. The high voltage conductor passes through the bushing made of some insulating material (e.g., porcelain, steatite). Although there are several types of bushing (e.g., condenser type, oil filled etc.), they perform the same function of insulating the conductor from earthed tank. The failure of the bushing can occur in two ways. Firstly, the breakdown may be caused by puncture i.e., dielectric failure of the insulating material of the bushing. Secondly, the breakdown may occur in the form of a flash-over between the exposed conductor at either end of the bushing and the earthed metal. Fig. 19.13 (ii) illustrates these two possibilities. The bushings are so designed that flash-over takes place before they get punctured. It is because the puncture generally renders the bushing insulation unserviceable and incapable of withstanding the normal voltage. On the other hand, a flash-over may result in comparatively harmless burning of the surface of the bushing which can then continue to give adequate service pending replacement.

Circuit breaker contacts:

The circuit breaker contacts are required to carry normal as well as short-circuit current. In carrying the normal current, it is desirable that the temperature should not rise above the specified limits and that there should be low voltage drop at the point of contact. In carrying breaking and making short-circuit currents, the chief effects to be dealt with are melting and Vaporization by the heat of the arc and those due to electromagnetic forces. Therefore, the design of contacts is of considerable importance for satisfactory operation of the circuit breakers. There are three types of circuit breaker contacts viz.

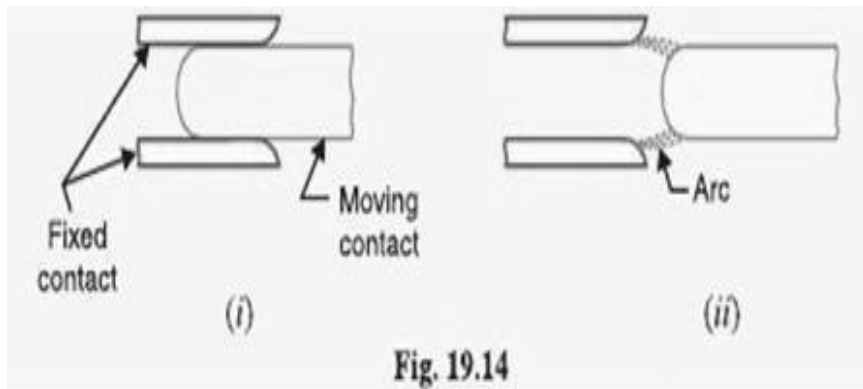

Fig. 19.14

(a) **Tulip type contacts:** Fig. 19.14 (i) shows the Tulip type contact. It consists of moving contact which moves inside the fixed contacts. At contact separation, the arc is generally established between the tips of the fixed contacts and the tip of the moving contact as shown in Fig. 19.14 (ii). The advantage of this type of contact is that arcing is confined to the regions which are not in contact in the fully engaged position.

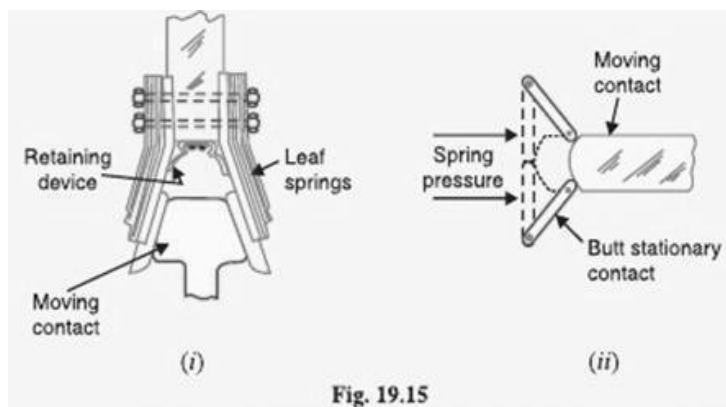

Fig. 19.15

(b) **Finger and wedge contacts:** Fig. 19.15 (i) shows the finger and wedge type contact. This type of contact is

largely used for low-voltage oil circuit breakers owing to the general unsuitability for use with arc control devices.

(c) **Butt contacts:** Fig. 19.15 (ii) shows the butt type contact and is formed by the springs and the moving contact. It possesses two advantages. Firstly, spring pressure is available to assist contact separation. This is useful in single-break oil circuit breakers and air-blast circuit breakers where relatively small —loop forces are available to assist in opening. Secondly, there is no grip force so that this type of contact is especially suitable for higher short circuit rating.

Instrument transformers:

In a modern power system, the circuits operate at very high voltages and carry current of thousands of amperes. The measuring instruments and protective devices cannot work satisfactorily if mounted directly on the power lines. This difficulty is overcome by installing instrument transformers on the power lines. The function of these instrument transformers is to transform voltages or currents in the power lines to values which are convenient for the operation of measuring instruments and relays.

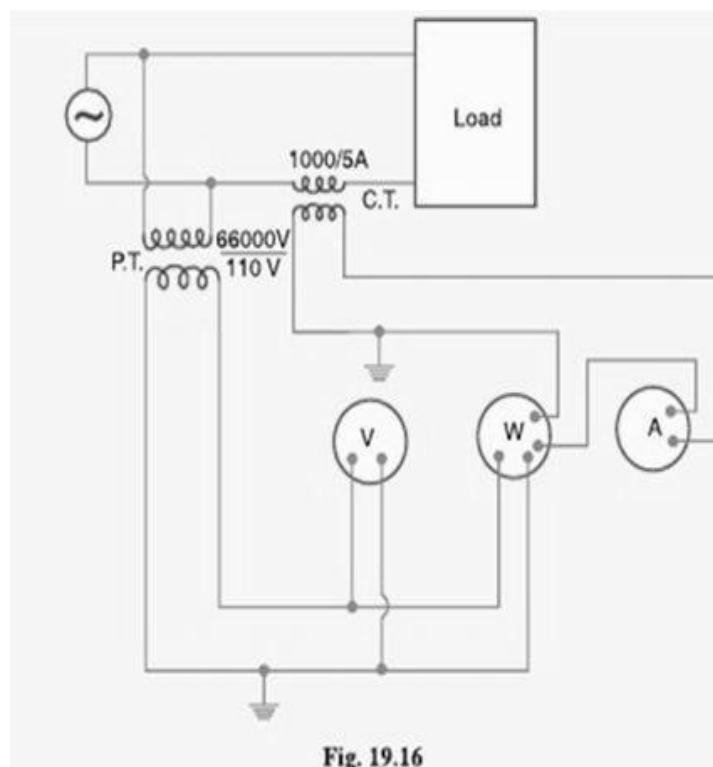

There are two types of instrument transformers viz.

1. Current transformer (C.T.)
2. Potential transformer (P.T.)

The primary of current transformer is connected in the power line. The secondary winding provides for

the instruments and relays a current which is a constant fraction of the current in the line similarly, a potential transformer is connected with its primary in the power line. The secondary provides for the instruments and relays a voltage which is a known fraction of the line voltage. Fig. 19.16 shows the use of instrument transformers. The

*potential transformer rated 66,000/110V provides a voltage supply for the potential coils of voltmeter and wattmeter. The current transformer rated 1000/5 A supplies current to the current coils of wattmeter and ammeter.

The use of instrument transformers permits the following advantages:

- (a) They isolate the measuring instruments and relays from high-voltage power circuits.
- (b) The leads in the secondary circuits carry relatively small voltages and currents. This permits to use wires of smaller size with minimum insulation.

Bus-bars and conductors: The current carrying members in a circuit breaker consist of fixed and moving contacts and the conductors connecting these to the points external to the breaker. If the switchgear is of outdoor type, these connections are connected directly to the overhead lines. In case of indoor switchgear, the incoming conductors to the circuit breaker are connected to the bus bars.

Circuit Breaker Ratings:

A circuit breaker may be called upon to operate under all conditions. However, major duties are imposed on the circuit breaker when there is a fault on the system in which it is connected. Under fault conditions, a circuit breaker is required to perform the following three duties:

- (i) It must be capable of opening the faulty circuit and breaking the fault current.
- (ii) It must be capable of being closed on to a fault.
- (iii) It must be capable of carrying fault current for a short time while another circuit breaker (in series) is clearing the fault.

Corresponding to the above mentioned duties, the circuit breakers have three ratings viz.

1. Breaking capacity
2. Making capacity and
3. Short-time capacity.

Breaking capacity: It is current (r.m.s.) that a circuit breaker is capable of breaking at given recovery voltage and under specified conditions (e.g., power factor, rate of rise of restriking voltage).

The breaking capacity is always stated at the r.m.s. value of fault Current at the instant of contact separation. When a fault occurs, there is considerable asymmetry in the fault current due to the Presence of a d.c. component. The d.c. component dies away rapidly, a typical decrement factor being 0.8 per cycle. Referring to

Fig. 19.24, the contacts are separated at DD' At this instant, the fault current has

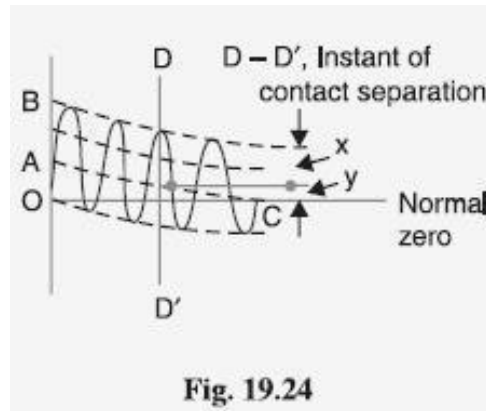

x = maximum value of a.c.

component y = d.c. component

Symmetrical breaking current \equiv r.m.s. value of a.c. component = $x/\sqrt{2}$

Asymmetrical breaking current = r.m.s. value of total current = $\sqrt{((x/\sqrt{2})^2 + y^2)}$

It is a common practice to express the breaking capacity in MVA by taking into account the rated breaking current and rated service voltage. Thus, if I is the rated breaking current in amperes and V is the rated service line voltage in volts, then for a 3-phase circuit,

$$\text{Breaking capacity} = \sqrt{3} \text{ *rated voltage in KV *rated current in KA}$$

In India (or Britain), it is a usual practice to take breaking current equal to the symmetrical breaking current. However, American practice is to take breaking current equal to asymmetrical breaking current. Thus the American rating given to a circuit breaker is higher than the Indian or British rating.

It seems to be illogical to give breaking capacity in MVA since it is obtained from the product of Short-circuit current and rated service voltage. When the short-circuit current is flowing, there is only a small voltage across the breaker contacts, while the service voltage appears across the contacts only after the current has been interrupted. Thus MVA rating is the product of two quantities which do not exist simultaneously in the circuit.

Therefore, the *agreed international standard of specifying breaking capacity is defined as the rated symmetrical breaking current at a rated voltage.

Making capacity:

There is always a possibility of closing or making the circuit under short circuit conditions. The capacity of a breaker to —make current depends upon its ability to withstand and close successfully against the effects of electromagnetic forces. These forces are proportional to the square of maximum instantaneous current on closing. Therefore, making capacity is stated in terms of a peak value of current instead of r.m.s. value.

The peak value of current (including d.c. component) during the first cycle of current wave after the closure of circuit breaker is known as making capacity.

It may be noted that the definition is concerned with the first cycle of current wave on closing the circuit breaker. This is because the maximum value of fault current possibly occurs in the first cycle only when maximum asymmetry occurs in any phase of the breaker. In other words, the making current is equal to the maximum value of asymmetrical current. To find this value, we must multiply symmetrical breaking current by

$\sqrt{2}$ to convert this from r.m.s. to peak, and then by 1.8 to include the —doubling effect of maximum asymmetry. The total multiplication factor becomes $\sqrt{2} \times 1.8 = 2.55$.

$$\text{Making capacity} = 2.55 \times \text{Symmetrical breaking capacity}$$

Short-time rating:

It is the period for which the circuit breaker is able to carry fault current while remaining closed. Sometimes a fault on the system is of very temporary nature and persists for 1 or 2 seconds after which the fault is automatically cleared. In the interest of continuity of supply, the breaker should not trip in such situations. This means that circuit breakers should be able to carry high current safely for some specified period while remaining closed i.e., they should have proven short-time rating. However, if the fault persists for duration longer than the specified time limit, the circuit breaker will trip, disconnecting the faulty section.

The short-time rating of a circuit breaker depends upon its ability to withstand The electromagnetic force effects and The temperature rise.

The oil circuit breakers have a specified limit of 3 seconds when the ratio of symmetrical breaking current to the rated normal current does not exceed 40. However, if this ratio is more than 40, then the specified limit is 1 second.

Normal current rating:

It is the r.m.s. value of current which the circuit breaker is capable of carrying continuously at its rated frequency under specified conditions. The only limitation in this case is the temperature rise of current-carrying parts.

Circuit Breaker

Classification of Circuit Breakers:

There are several ways of classifying the circuit breakers. However, the most general way of classification is on the basis of medium used for arc extinction. The medium used for arc extinction is usually oil, air, sulphur hexafluoride (SF₆) or vacuum. Accordingly, circuit breakers may be classified into:

1. **Oil circuit breakers:** which employ some insulating oil (e.g., transformer oil) for arc extinction?
2. **Air-blast circuit breakers:** in which high pressure air-blast is used for extinguishing the arc.
3. **Sulphur hexafluoride circuit breakers:** in which sulphur hexafluoride (SF₆) gas is used for arc extinction.
4. **Vacuum circuit breakers:** in which vacuum is used for arc extinction.

Each type of circuit breaker has its own advantages and disadvantages. In the following sections, we shall discuss the construction and working of these circuit breakers with special emphasis on the way the arc extinction is facilitated.

Oil Circuit Breakers:

In such circuit breakers, some insulating oil (e.g., transformer oil) is used as an arc quenching medium. The contacts are opened under oil and an arc is struck between them. The heat of the arc evaporates the surrounding oil and dissociates it into a substantial volume of gaseous hydrogen at high pressure. The hydrogen gas occupies a volume about one thousand times that of the oil decomposed. The oil is, therefore, pushed away from the arc and an expanding hydrogen gas bubble surrounds the arc region and adjacent portions of the contacts (See Fig. 19.2). The arc extinction is facilitated mainly by two processes. Firstly, the hydrogen gas has high heat conductivity and cools the arc, thus aiding the de-ionization of the medium between the contacts. Secondly, the gas sets up turbulence in the oil and forces it into the space between contacts, thus eliminating the arcing products from the arc path. The result is that arc is extinguished and circuit current †interrupted.

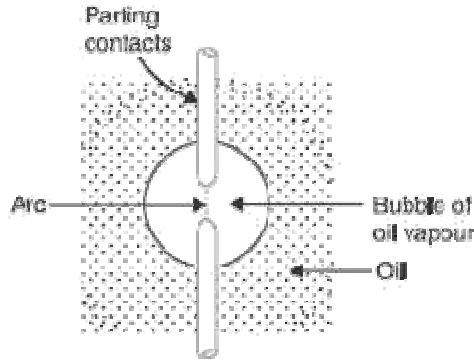

Fig. 19.2

The advantages of oil as an arc quenching medium are:

1. It absorbs the arc energy to decompose the oil into gases which have excellent cooling properties.
2. It acts as an insulator and permits smaller clearance between live conductors and earthed components.
3. The surrounding oil presents cooling surface in close proximity to the arc.

The disadvantages of oil as an arc quenching medium are:

1. It is inflammable and there is a risk of a fire.
2. It may form an explosive mixture with air
3. The arcing products (e.g., carbon) remain in the oil and its quality deteriorates with successive operations. This necessitates periodic checking and replacement of oil.

Types of Oil Circuit Breakers:

The oil circuit breakers find extensive use in the power system. These can be classified into the following

types:

1. Bulk oil circuit breakers
2. Low oil circuit breakers

Bulk oil circuit breakers:

Which use a large quantity of oil. The oil has to serve two purposes. Firstly, it extinguishes the arc during opening of contacts and secondly, it insulates the current conducting parts from one another and from the earthed tank. Such circuit breakers may be classified into:

1. Plain break oil circuit breakers
2. Arc control oil circuit breakers.

In the former type, no special means is available for controlling the arc and the contacts are directly

exposed to the whole of the oil in the tank. However, in the latter type, special arc control devices are employed to get the beneficial action of the arc as efficiently as possible.

Plain Break Oil Circuit Breakers:

A plain-break oil circuit breaker involves the simple process of separating the contacts under the whole of the oil in the tank. There is no special system for arc control other than the increase in length caused by the separation of contacts. The arc extinction occurs when a certain critical gap between the contacts is reached. The plain-break oil circuit breaker is the earliest type from which all other circuit breakers have developed. It has a very simple construction. It consists of fixed and moving contacts enclosed in a strong weather-tight earthed tank containing oil up to a certain level and an air cushion above the oil level. The air cushion provides sufficient room to allow for the reception of the arc gases without the generation of unsafe pressure in the dome of the circuit breaker. It also absorbs the

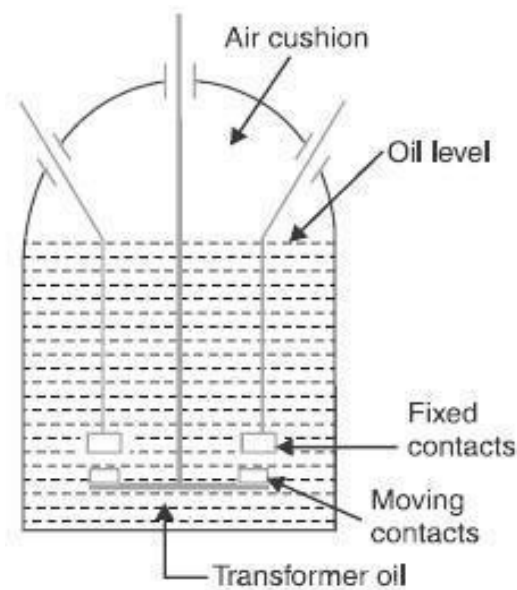

Fig. 19.3

mechanical shock of the upward oil movement. Fig. 19.3 shows a double break plain oil circuit breaker. It is called a double break because it provides two breaks in series.

Under normal operating conditions, the fixed and moving contacts remain closed and the breaker carries the normal circuit Current. When a fault occurs, the moving contacts are pulled down by the protective system and an arc is struck which vaporizes the oil mainly into hydrogen gas.

The arc extinction is facilitated by the following processes:

- The hydrogen gas bubble generated around the arc cools the arc column and aids the deionization of the medium between the contacts.
- The gas sets up turbulence in the oil and helps in eliminating the arcing products from the arc path.
- As the arc lengthens due to the separating contacts, the dielectric strength of the medium is increased.

The result of these actions is that at some critical gap length, the arc is extinguished and the circuit current is interrupted.

Disadvantages:

- There is no special control over the arc other than the increase in length by separating the moving contacts. Therefore, for successful Interruption, Long arc length is necessary.
- These breakers have long and inconsistent arcing times.
- These breakers do not permit high speed interruption.

Due to these disadvantages, plain-break oil circuit breakers are used only for low voltage applications where high breaking-capacities are not important. It is a usual practice to use such breakers for low capacity installations for Voltages not exceeding 11 kV.

Arc Control Oil Circuit Breakers:

In case of plain-break oil circuit breaker discussed above, there is very little artificial control over the arc. Therefore, comparatively long arc length is essential in order that turbulence in the oil caused by the gas may assist in quenching it. However, it is necessary and desirable that final arc extinction should occur while the contact gap is still short. For this purpose, some arc control is incorporated and the breakers are then called arc control circuit breakers.

There are two types of such breakers, namely:

1. **Self-blast oil circuit breakers**— in which arc control is provided by internal means i.e. the arc itself is employed for its own extinction efficiently.
2. **Forced-blast oil circuit breakers**— in which arc control is provided by mechanical means external to the circuit breaker.

Self-blast oil circuit breakers:

In this type of circuit breaker, the gases produced during arcing are confined to a small volume by the use of an insulating rigid pressure chamber or pot surrounding the contacts. Since the space available for the arc gases is restricted by the chamber, a very high pressure is developed to force the oil and gas through or around the arc to extinguish it. The magnitude of pressure developed depends upon the value of fault current to be interrupted. As the pressure is generated by the arc itself, therefore, such breakers are some times called self-generated pressure oil circuit breakers.

The pressure chamber is relatively cheap to make and gives reduced final arc extinction gap length and arcing time as against the plain-break oil circuit breaker. Several designs of pressure chambers (sometimes called explosion pots) have been developed and a few of them are described below:

Plain explosion pot:

It is a rigid cylinder of insulating material and encloses the fixed and moving contacts (See Fig. 19.4). The moving contact is a cylindrical rod passing through a restricted opening (called throat) at the bottom. When a fault occurs, the contacts get separated and an arc is struck between them. The heat of the arc decomposes oil into a gas at very high pressure in the pot. This high pressure forces the oil and gas through and round the arc to extinguish it. If the final arc extinction does not take place while the moving contact is still within the pot, it occurs immediately after the moving contact leaves the pot. It is because emergence of the moving contact from the pot is followed by a violent rush of gas and oil through the throat producing rapid extinction.

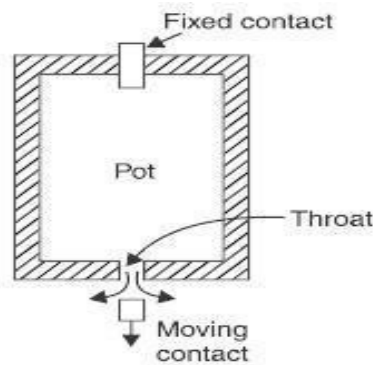

Fig. 19.4

The principal limitation of this type of pot is that it cannot be used for very low or for very high fault currents. With low fault currents, the pressure developed is small, thereby increasing the arcing time. On the other hand, with high fault currents, the gas is produced so rapidly that explosion pot is liable to burst due to high pressure. For this reason, plain explosion pot operates well on moderate short-circuit currents only where the rate of gas evolution is moderate

Cross jet explosion pot:

This type of pot is just a modification of plain explosion pot and is illustrated in Fig. 19.5. It is

made of insulating material and has channels on one side which act as arc splitters. The arc splitters help in increasing the arc length, thus facilitating arc extinction. When a fault occurs, the moving contact of the circuit breaker begins to separate. As the moving contact is withdrawn, the arc is initially struck in the top of the pot. The gas generated by the arc exerts pressure on the oil in the back passage. When the moving contact uncovers the arc splitter ducts, fresh oil is forced *across the arc path. The arc is, therefore, driven sideways into the —arc splitters| which increase the arc length, causing arc extinction.

The cross-jet explosion pot is quite efficient for interrupting heavy fault currents. However, for low fault currents,

the gas pressure is †small and consequently the pot does not give a satisfactory operation.

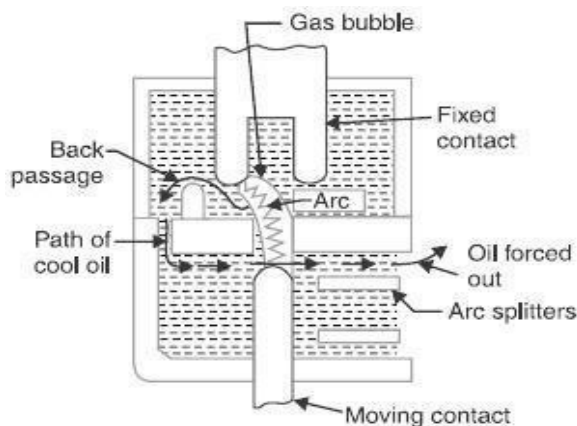

Fig. 19.5

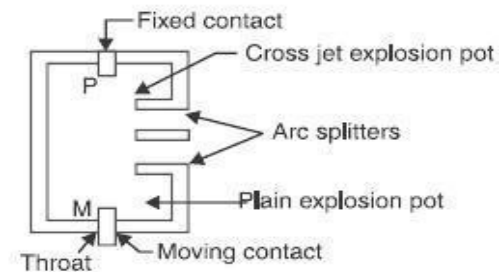

Fig. 19.6

Self-compensated explosion pot:

This type of pot is essentially a combination of plain explosion pot and cross jet explosion pot. Therefore, it can interrupt low as well as heavy short circuit currents with reasonable accuracy. Fig. 19.6 shows the schematic diagram of self-compensated explosion pot. It consists of two chambers; the upper chamber is the cross-jet explosion pot with two arc splitter ducts while the lower one is the plain explosion pot. When the short- circuit current is heavy, the rate of generation of gas is very high and the device behaves as a cross-jet explosion pot. The arc extinction takes place when the moving contact uncovers the first or second arc splitter duct. However, on low short-circuit currents, the rate of gas generation is small and the tip of the moving contact has the time to reach the lower chamber. During this time, the gas builds up sufficient pressure as there is very little leakage through arc splitter ducts due to the obstruction offered by the arc path and right angle bends. When the moving contact comes out of the throat, the arc is extinguished by plain pot action.

It may be noted that as the severity of the short circuit current increases, the device operates less and less as a plain explosion pot and more and more as a cross-jet explosion pot. Thus the tendency is to make the control self- compensating over the full range of fault currents to be interrupted.

Forced-blast oil circuit breakers:

In the self-blast oil circuit breakers discussed above, the arc itself generates the necessary pressure to force the oil across the arc path. The major limitation of such breakers is that arcing times tend to be long and inconsistent when operating against currents considerably less than the rated currents. It is because the gas generated is much reduced at low values of fault currents. This difficulty is overcome in forced-blast oil circuit breakers in which the necessary pressure is generated by external mechanical means independent of the fault currents to be broken.

In a forced -blast oil circuit breaker, oil pressure is created by the piston-cylinder arrangement. The movement of the piston is mechanically coupled to the moving contact. When a fault occurs, the contacts get separated by the protective system and an arc is struck between the contacts. The piston forces a jet of oil towards the contact gap to extinguish the arc. It may be noted that necessary oil pressure produced does not in any way depend upon the fault current to be broken.

Advantages:

1. Since oil pressure developed is independent of the fault current to be interrupted, the performance at low currents is more consistent than with self-blast oil circuit breakers.
2. The quantity of oil required is reduced considerably.

Low Oil Circuit Breakers:

In the bulk oil circuit breakers discussed so far, the oil has to perform two functions. Firstly, it acts as an arc quenching medium and secondly, it insulates the live parts from earth. It has been found that only a small percentage of oil is actually used for arc extinction while the major part is utilized for insulation purposes. For this reason, the quantity of oil in bulk oil circuit breakers reaches a very high figure as the system voltage increases. This not only increases the expenses, tank size and weight of the breaker but it also increase the fire risk and maintenance problems.

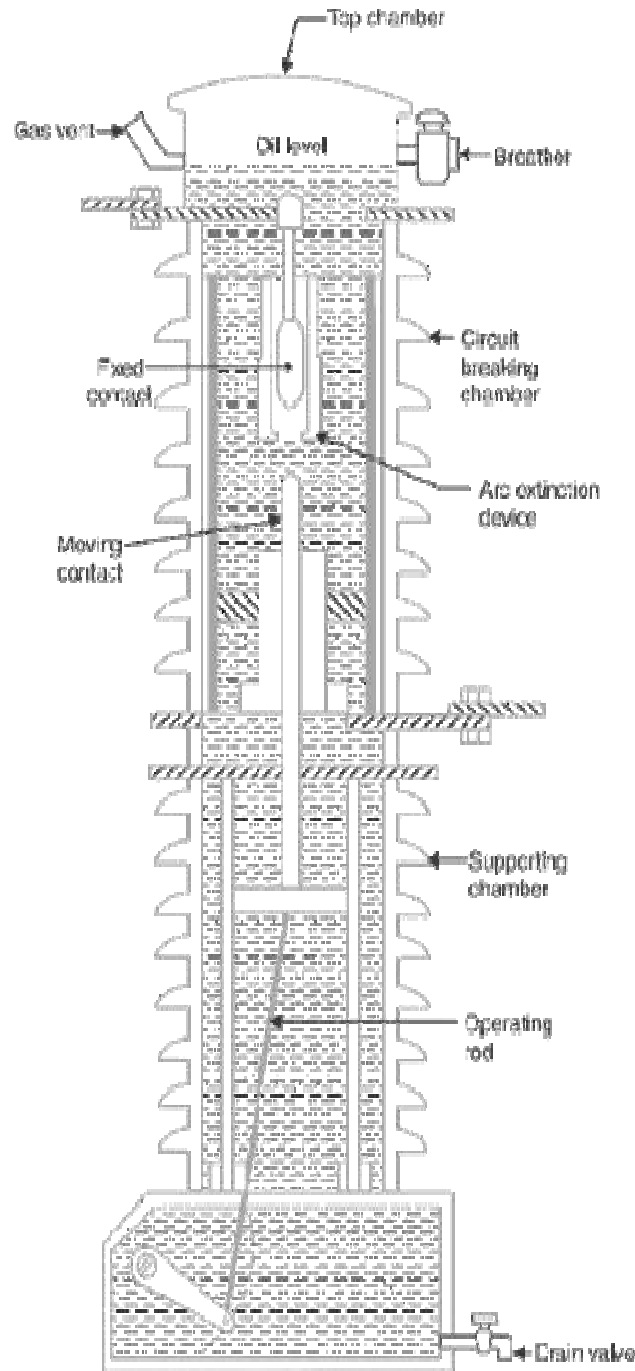

Fig. 19.7 Low-oil Circuit Breaker

The fact that only a small percentage of oil (about 10% of total) in the bulk oil circuit breaker is actually used for arc extinction leads to the question as to why the remainder of the oil, that is not immediately surrounding the device, should not be omitted with consequent saving in bulk, weight and fire risk. This led to the development of low-oil circuit breaker. A low oil circuit breaker employs solid materials for insulation purposes and uses a small quantity of oil which is just sufficient for arc extinction. As regards quenching the arc, the oil behaves identically in bulk as well as low oil circuit breaker. By using suitable arc control devices, the arc extinction can be further facilitated in a low oil circuit breaker.

Construction:

Fig 19.7 shows the cross section of a single phase low oil circuit breaker. There are two compartments separated from each other but both filled with oil. The upper chamber is the circuit breaking chamber while the lower one is the supporting chamber. The two chambers are separated by a partition and oil from one chamber is prevented from mixing with the other chamber. This arrangement permits two advantages. Firstly, the circuit breaking chamber requires a small volume of oil which is just enough for arc extinction. Secondly, the amount of oil to be replaced is reduced as the oil in the supporting chamber does not get contaminated by the arc.

Supporting chamber:

It is a porcelain chamber mounted on a metal chamber. It is filled with oil which is physically separated from the oil in the circuit breaking compartment. The oil inside the supporting chamber and the annular space formed between the porcelain insulation and bakelised paper is employed for insulation purposes only.

Circuit-breaking chamber:

It is a porcelain enclosure mounted on the top of the supporting compartment. It is filled with oil and has the following parts:

1. upper and lower fixed contacts
2. Moving contact
3. Turbulator

The moving contact is hollow and includes a cylinder which moves down over a fixed piston. The turbulator is an arc control device and has both axial and radial vents. The axial venting ensures the interruption of low currents whereas radial venting helps in the interruption of heavy currents.

Top chamber:

It is a metal chamber and is mounted on the circuit-breaking chamber. It provides expansion space for the oil in the circuit breaking compartment. The top chamber is also provided with a separator which prevents any loss of oil by centrifugal action caused by circuit breaker operation during fault conditions.

Operation:

Under normal operating conditions, the moving contact remains engaged with the upper fixed contact. When a fault occurs, the moving contact is pulled down by the tripping springs and an arc is

struck. The arc energy vaporizes the oil and produces gases under high pressure. This action constrains the oil to pass through a central hole in the moving contact and results in forcing series of oil through the respective passages of the tabulator. The process of tabulation is orderly one, in which the sections of the arc are successively quenched by the effect of separate streams of oil moving across each section in turn and bearing away its gases.

A low oil circuit breaker has the following advantages over a bulk oil circuit breaker:

1. It requires lesser quantity of oil.
2. It requires smaller space.
3. There is reduced risk of fire.
4. Maintenance problems are reduced.

A low oil circuit breaker has the following disadvantages as compared to a bulk oil circuit breaker:

1. Due to smaller quantity of oil, the degree of carbonization is increased.
2. There is a difficulty of removing the gases from the contact space in time.
3. The dielectric strength of the oil deteriorates rapidly due to high degree of carbonization.

Maintenance of Oil Circuit Breakers:

The maintenance of oil circuit breaker is generally concerned with the checking of contacts and dielectric strength of oil. After a circuit breaker has interrupted fault currents a few times or load currents several times, its contacts may get burnt by arcing and the oil may lose some of its dielectric strength due to carbonization. This results in the reduced rupturing capacity of the breaker. There fore, it is a good practice to inspect the circuit breaker at regular intervals of 3 or 6 months.

During inspection of the breaker, the following points should be kept in view:

- Check the current carrying parts and arcing contacts. If the burning is severe, the contacts should be replaced.
- Check the dielectric strength of the oil. If the oil is badly discolored, it should be changed or reconditioned. The oil in good condition should withstand 30 kV for one minute in a standard oil testing cup with 4 mm gap between electrodes.
- Check the insulation for possible damage. Clean the surface and remove carbon deposits with a strong and dry fabric.
- Check the oil level.
- Check closing and tripping mechanism.

Air-Blast Circuit Breakers:

These breakers employ a high pressure *air-blast as an arc quenching medium. The contacts are opened in a flow of air-blast established by the opening of blast valve. The air-blast cools the arc and sweeps away the arcing products to the atmosphere. This rapidly increases the dielectric strength of the medium between contacts and prevents from re-establishing the arc. Consequently, the arc is extinguished and flow of current is interrupted.

An air-blast circuit breaker has the following advantages over an oil circuit breaker:

1. The risk of fire is eliminated.
2. The arcing products are completely removed by the blast whereas the oil deteriorates with successive operations; the expense of regular oil replacement is avoided.
3. The growth of dielectric strength is so rapid that final contact gap needed for arc extinction is very small. This reduces the size of the device.
4. The arcing time is very small due to the rapid build up of dielectric strength between contacts. Therefore, the arc energy is only a fraction of that in oil circuit breakers, thus resulting in less burning of contacts.
5. Due to lesser arc energy, air-blast circuit breakers are very suitable for conditions where frequent operation is required.
6. The energy supplied for arc extinction is obtained from high pressure air and is independent of the current to be interrupted.

The use of air as the arc quenching medium offers the following disadvantages:

1. The air has relatively inferior arc extinguishing properties.
2. The air-blast circuit breakers are very sensitive to the variations in the rate of rise of re striking voltage.
3. Considerable maintenance is required for the compressor plant which supplies the air-blast.
4. The air blast circuit breakers are finding wide applications in high voltage installations.
5. Majority of the circuit breakers for voltages beyond 110 kV are of this type.

Types of Air-Blast Circuit Breakers:

Depending upon the direction of air-blast in relation to the arc, air-blast circuit breakers are classified into:

1. **Axial-blast type** in which the air-blast is directed along the arc path as shown in Fig. 19.8(i).
2. **Cross-blast type** in which the air-blast is directed at right angles to the arc path as shown in Fig. 19.8 (ii).
3. **Radial-blast type** in which the air-blast is directed radially as shown in Fig. 19.8 (iii).

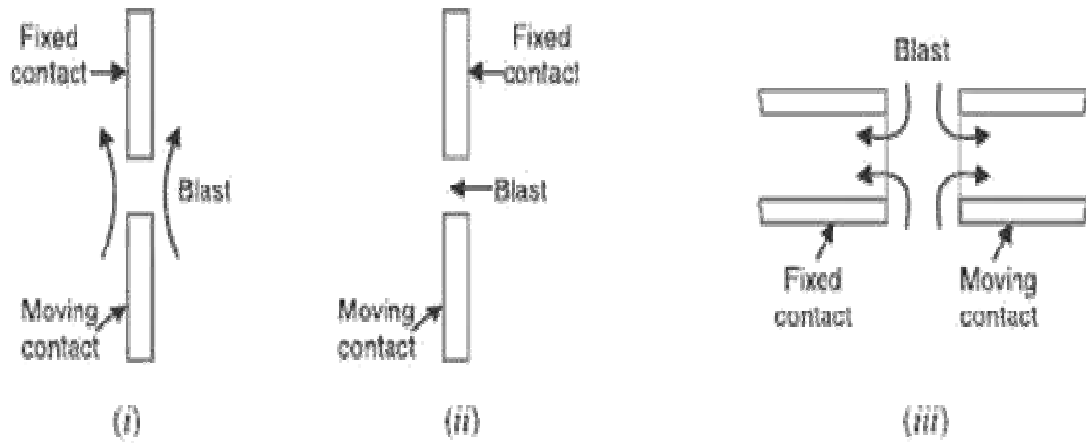

Fig. 19.8

Axial-blast air circuit breaker:

Fig 19.9 shows the essential components of a typical axial blast air circuit breaker. The fixed and moving contacts are held in the closed position by spring pressure under normal conditions. The air reservoir is connected to the arcing chamber through an air valve. This valve remains closed under normal conditions but opens automatically by the tripping impulse when a fault occurs on the system.

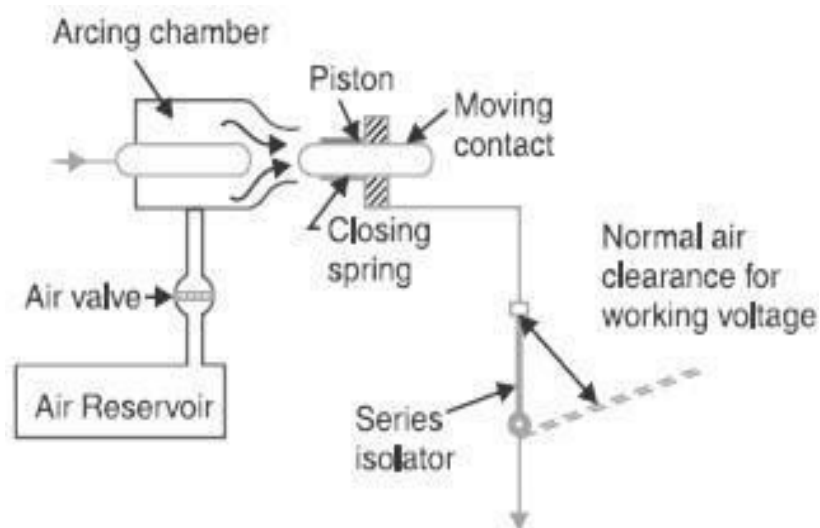

Fig. 19.9

When a fault occurs, the tripping impulse causes opening of the air valve which connects the circuit breaker reservoir to the arcing chamber. The high pressure air entering the arcing chamber pushes away the moving contact against spring pressure. The moving contact is separated and an arc is struck. At the same time, high pressure air blast flows along the arc and takes away the ionized gases along with it. Consequently, the arc is extinguished and current flow is interrupted.

It may be noted that in such circuit breakers, the contact separation required for interruption is generally small (1.75 cm or so). Such a small gap may constitute inadequate clearance for the normal service voltage. Therefore, an isolating switch is incorporated as a part of this type of circuit breaker. This switch opens immediately after fault interruption to provide the necessary clearance for insulation.

Cross-blast air breaker:

In this type of circuit breaker, an air-blast is directed at right angles to the arc. The cross-blast lengthens and forces the arc into a suitable chute for arc extinction. Fig. 19.10 shows the essential parts of a typical cross- blast Air circuit breaker. When the moving contact is withdrawn, an arc is struck between the fixed and moving contacts. The high pressure cross-blast Forces the arc into a chute consisting of arc splitters and baffles. The splitters serve to increase the length of the arc and baffles give improved cooling. The result is that arc is extinguished and flow of Current is interrupted. Since blast pressure is same for all currents, the inefficiency at low currents is eliminated. The final gap for interruption is great enough to give normal insulation clearance so that a series isolating switch is not necessary.

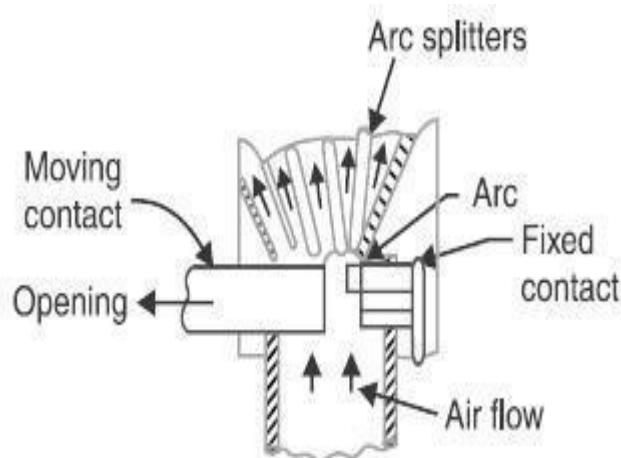

Fig. 19.10

Sulphur Hexafluoride (SF₆) Circuit Breakers:

In such circuit breakers, sulphur hexafluoride (SF₆) gas is used as the arc quenching medium. The SF₆ is an electro-negative gas and has a strong tendency to absorb free electrons. The contacts of the breaker are opened in a high pressure flow of SF₆ gas and an arc is struck between them. The conducting free electrons in the arc are rapidly captured by the gas to form relatively immobile negative ions. This loss of conducting electrons in the arc quickly builds up enough insulation strength to extinguish the arc. The SF₆ circuit breakers have been found to be very effective for high power and high voltage service.

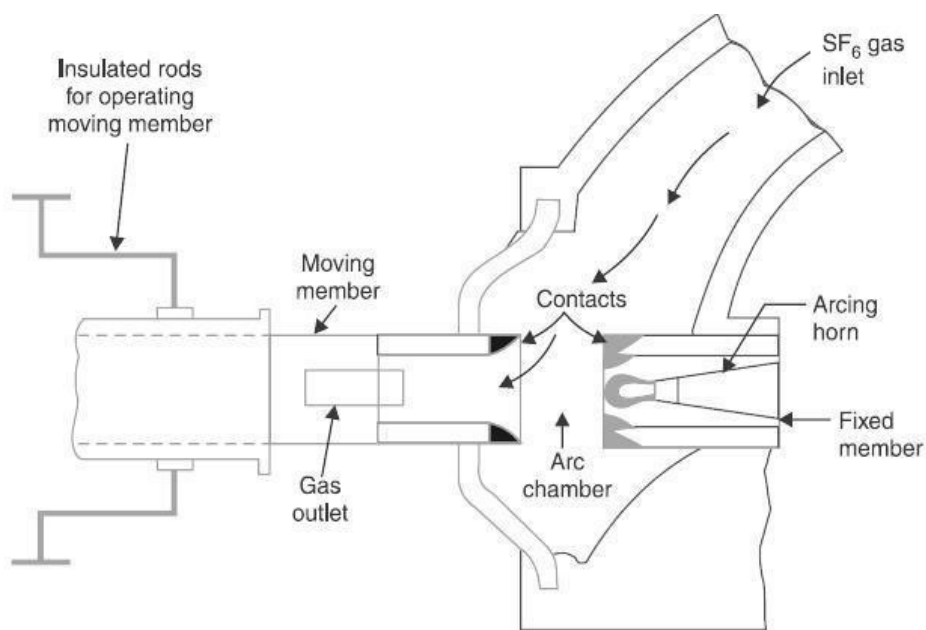

Fig. 19.11

Construction:

Fig. 19.11 shows the parts of a typical SF₆ circuit breaker. It consists of fixed and moving contacts enclosed in a chamber (called arc interruption chamber) containing SF₆ gas. This chamber is connected to SF₆ gas reservoir. When the contacts of breaker are opened, the valve mechanism permits a high pressure SF₆ gas from the reservoir to flow towards the arc interruption chamber. The fixed contact is a hollow cylindrical current carrying contact fitted with an arc horn. The moving contact is also a hollow cylinder with rectangular holes in the sides to permit the SF₆ gas to let out through these holes after flowing along and across the arc. The tips of fixed contact, moving contact and arcing horn are coated with copper-tungsten arc resistant material. Since SF₆ gas is costly, it is reconditioned and reclaimed by suitable auxiliary system after each operation of the breaker.

Working:

In the closed position of the breaker, the contacts remain surrounded by SF₆ gas at a pressure of about 2.8kg/cm. When the breaker operates, the moving contact is pulled apart and an arc is struck between the contacts. The movement of the moving contact is synchronized with the opening of a valve which permits SF₆ gas at 14 kg/cm pressure from the reservoir to the arc interruption chamber. The high pressure flow of SF₆ rapidly absorbs the free electrons in the arc path to form immobile negative ions which are ineffective as charge carriers. The result is that the medium between the contacts quickly builds up high dielectric strength and causes the extinction of the arc. After the breaker operation (i.e., after arc extinction), the valve is closed by the action of a set of springs.

Advantages:

Due to the superior arc quenching properties of SF₆ gas, the SF₆ circuit breakers have many advantages over oil or air circuit breakers. Some of them are listed below:

1. Due to the superior arc quenching property of SF₆, such circuit breakers have very short arcing time.
2. Since the dielectric strength of SF₆ gas is 2 to 3 times that of air, such breakers can interrupt much larger currents.
3. The SF₆ circuit breaker gives noiseless operation due to its closed gas circuit and no exhaust to atmosphere unlike the air blast circuit breaker
4. The closed gas enclosure keeps the interior dry so that there is no moisture problem.
5. There is no risk of fire in such breakers because SF₆ gas is non-inflammable.
6. There are no carbon deposits so that tracking and insulation problems are eliminated.
7. The SF₆ breakers have low maintenance cost, light foundation requirements and minimum auxiliary equipment.
8. Since SF₆ breakers are totally enclosed and sealed from atmosphere, they are particularly suitable where explosion hazard exists e.g., coal mines.

Disadvantages:

1. SF₆ breakers are costly due to the high cost of SF₆.
2. Since SF₆ gas has to be reconditioned after every operation of the breaker, additional equipment is required for this purpose.

Applications:

A typical SF₆ circuit breaker consists of interrupter units each capable of dealing with currents up to 60 kA and voltages in the range of 50—80 kV. A number of units are connected in series according to the system

voltage. SF6 circuit breakers have been developed for voltages 115 kV to 230 kV, power ratings 10 MVA to 20 MVA and interrupting time less than 3 cycles.

Vacuum Circuit Breakers (VC B):

In such breakers, vacuum (degree of vacuum being in the range from 10^{-4} to 10^{-6} torr) is used as the arc quenching medium. Since vacuum offers the highest insulating strength, it has far superior arc quenching properties than any other medium. For example, when contacts of a breaker are opened in vacuum, the interruption occurs at first current zero with dielectric strength between the contacts building up at a rate thousands of times higher than that obtained with other circuit breakers.

Principle:

The production of arc in a vacuum circuit breaker and its extinction can be explained as follows:

When the contacts of the breaker are opened in vacuum (10^{-4} to 10^{-6} torr), an arc is produced between the contacts by the ionization of metal vapours of contacts. However, the arc is quickly extinguished because the metallic vapours, electrons and ions produced during arc rapidly condense on the surfaces of the circuit breaker contacts, resulting in quick recovery of dielectric strength. The reader may note the salient feature of vacuum as an arc quenching medium. As soon as the arc is produced in vacuum, it is quickly extinguished due to the fast rate of recovery of dielectric strength in vacuum.

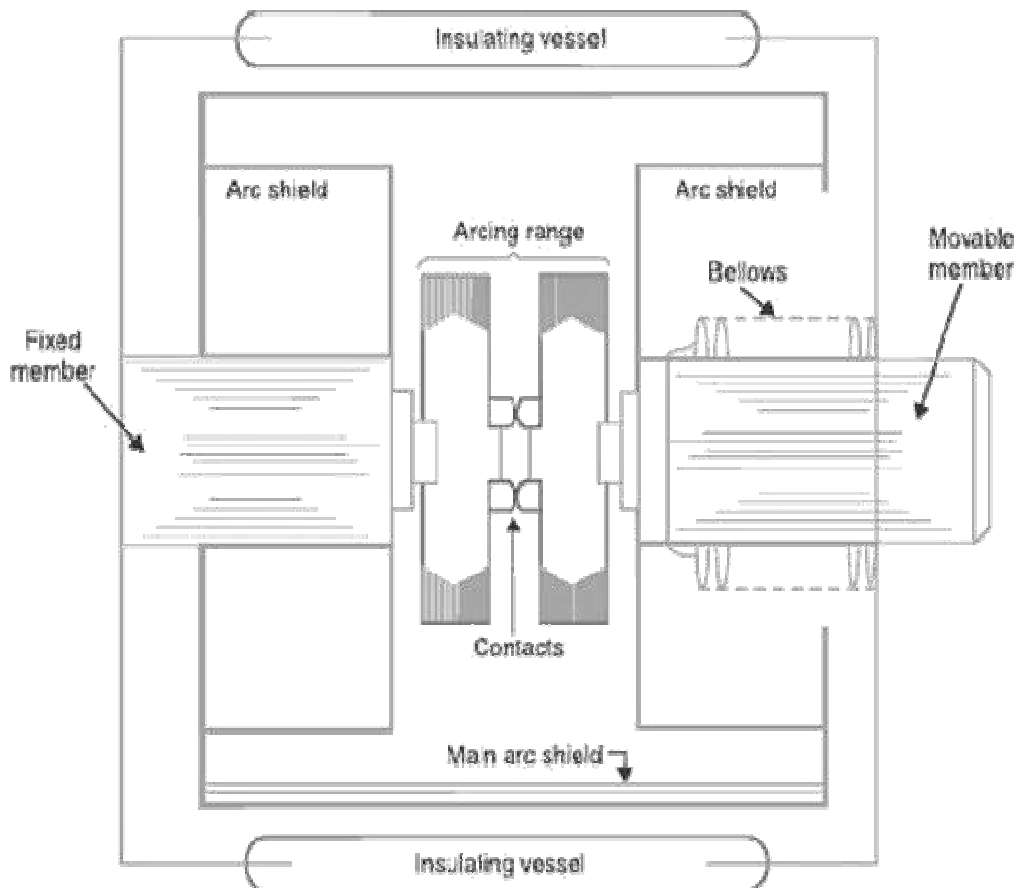

Fig. 19.12

Construction:

Fig. 19.12 shows the parts of a typical vacuum circuit breaker. It consists of fixed contact, moving contact and arc shield mounted inside a vacuum chamber. The movable member is connected to the control mechanism by stainless steel bellows. This enables the permanent sealing of the vacuum chamber so as to eliminate the possibility of leak. A glass vessel or ceramic vessel is used as the outer insulating body. The arc shield prevents the deterioration of the internal dielectric strength by preventing metallic vapours falling on the inside surface of the outer insulating cover.

Working:

When the breaker operates, the moving contact separates from the fixed contact and an arc is struck between the contacts. The production of arc is due to the ionization of metal ions and depends very much upon the material of contacts. The arc is quickly extinguished because the metallic vapours, electrons and ions produced during arc are diffused in a short time and seized by the surfaces of moving and fixed members and shields. Since vacuum has very fast rate of recovery of dielectric strength, the arc extinction in a vacuum breaker occurs with a short contact separation (say 0.625 cm).

Vacuum circuit breakers have the following advantages:

1. They are compact, reliable and have longer life.
2. There is no generation of gas during and after operation.
3. They can interrupt any fault current. The outstanding feature of a V C B is that it can break any heavy fault current perfectly just before the contacts reach the definite open position.
4. They require little maintenance and are quiet in operation.
5. They have low arc energy.
6. They have low inertia and hence require smaller power for control mechanism.

Applications:

For a country like India, where distances are quite large and accessibility to remote areas difficult, the installation of such outdoor, maintenance free circuit breakers should prove a definite advantage. Vacuum circuit breakers are being employed for outdoor applications ranging from 22 kV to 66 kV. Even with limited rating of say 60 to 100 MVA, they are suitable for a majority of applications in rural areas.

Module – II

Electromagnetic and Static Relays

Introduction

In a power system consisting of generators, transformers, transmission and distribution circuits, it is inevitable that sooner or later some failure will occur somewhere in the system. When a failure occurs on any part of the system, it must be quickly detected and disconnected from the system.

There are two principal reasons for it. Firstly, if the fault is not cleared quickly, it may cause unnecessary interruption of service to the customers. Secondly, rapid disconnection of faulted apparatus limits the amount of damage to it and prevents the effects of fault from spreading into the system. The detection of a fault and disconnection of a faulty section or apparatus can be achieved by using fuses or relays in conjunction with circuit breakers. A fuse performs both detection and interruption functions automatically but its use is limited for the protection of low-voltage circuits only.

For high voltage circuits (say above 3.3 kV), relays and circuit breakers are employed to serve the desired function of automatic protective gear.

The detection of a fault and disconnection of a faulty section or apparatus can be achieved by using fuses or relays in conjunction with circuit breakers. A fuse performs both detection and interruption functions automatically but its use is limited for the protection of low-voltage circuits only.

For high voltage circuits (say above 3.3 kV), relays and circuit breakers are employed to serve the desired function of automatic protective gear.

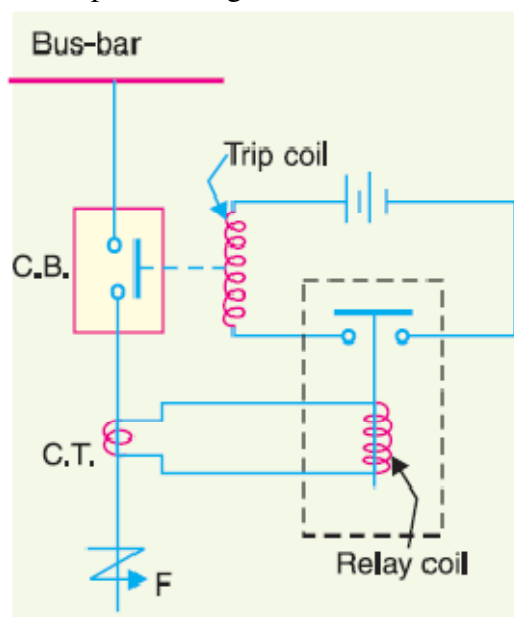

Operation Steps:

- When a short circuit occurs at point F on the transmission line, the current flowing in the line increases to an enormous value.
- This results in a heavy current flow through the relay coil, causing the relay to operate by closing its contacts.
- This in turn closes the trip circuit of the breaker, making the circuit breaker open and isolating the faulty section from the rest of the system.

In this way, the relay ensures the safety of the circuit equipment from damage and normal working of the healthy portion of the system.

Fundamental Requirements of Protective Relaying:

The principal function of protective relaying is to cause the prompt removal from service of any element of the power system. In order that protective relay system may perform this function satisfactorily, it should have the following qualities:

selectivity (ii) speed (iii) sensitivity (iv) reliability (v) simplicity (vi) economy

1. Selectivity:

It is the ability of the protective system to select correctly that part of the system in trouble and disconnect the faulty part without disturbing the rest of the system. The system can be divided into the following protection zones:

- (a) generators
- (b) low-tension switchgear
- (c) transformers
- (d) high-tension switchgear
- (e) transmission lines

It may be seen in the previous Fig. that there is certain amount of overlap between the adjacent protection zones.

For a failure within the region where two adjacent zones overlap, more breakers will be opened than the minimum necessary to disconnect the faulty section. But if there were no overlap, a failure in the region between zones would not lie in either region and, therefore, no breaker would be opened. For this reason, a certain amount of overlap is provided between the adjacent zones.

2- Speed:

The relay system should disconnect the faulty section as fast as possible for the following reasons:

- (a) Electrical apparatus may be damaged if they are made to carry the fault currents for a long time.
- (b) A failure on the system leads to a great reduction in the system voltage. If the faulty

section is not disconnected quickly, then the low voltage created by the fault may shut down consumers' motors and the generators on the system may become unstable.

(c) The high speed relay system decreases the possibility of development of one type of fault into the other more severe type.

3- Sensitivity.

It is the ability of the relay system to operate with low value of actuating quantity.

Sensitivity of a relay is a function of the volt-amperes input to the coil of the relay necessary to cause its operation.

4- Reliability. It is the ability of the relay system to operate under the pre-determined conditions.

5- Simplicity. The relaying system should be simple so that it can be easily maintained. Reliability is closely related to simplicity. The simpler the protection scheme, the greater will be its reliability.

6- Economy.

The most important factor in the choice of a particular protection scheme is the economic aspect. Sometimes it is economically unjustified to use an ideal scheme of protection and a compromise method has to be adopted. As a rule, the protective gear should not cost more than 5% of total cost. However, when the apparatus to be protected

is of utmost importance (e.g.generator, main transmission line etc.), economic considerations are often subordinated to reliability.

Basic Relays

Most of the relays used in the power system operate by virtue of the current and/or voltage supplied by current and voltage transformers connected in various combinations to the system element that is to be protected. Through the individual or relative changes in these two quantities, faults signal their presence, type and location to the protective relays. Having detected the fault, the relay operates the trip circuit which results in the opening of the circuit breaker and hence in the disconnection of the faulty circuit.

The electro-mechanical relays work on the following two main operating principles:

- (i) Electromagnetic attraction
- (ii) Electromagnetic induction

Electromagnetic Attraction Relays :

Electromagnetic attraction relays operate by virtue of an armature being attracted to

the poles of an electromagnet or a plunger being drawn into a solenoid. Such relays may be actuated by D.C. or A.C. quantities.

(i) **Attracted armature type relay.** Fig. 21.3 shows the schematic arrangement of an attracted armature type relay. It consists of a laminated electromagnet M carrying a coil C and a pivoted laminated armature. The armature is balanced by a counterweight and carries a pair of spring contact fingers at its free end. Under normal operating conditions, the current through the relay coil C is such that counterweight holds the armature in the position shown. However, when a short circuit occurs, the current through the relay coil increases sufficiently and the relay armature is attracted upwards. The contacts on the relay armature bridge a pair of stationary contacts attached to the relay frame. This completes the trip circuit which results in the opening of the circuit breaker and, therefore, in the disconnection of the faulty circuit.

The minimum current at which the relay armature is attracted to close the trip circuit is called *pickup* current. It is a usual practice to provide a number of tapings on the relay coil so that the number of turns in use and hence the setting value at which the relay operates can be varied.

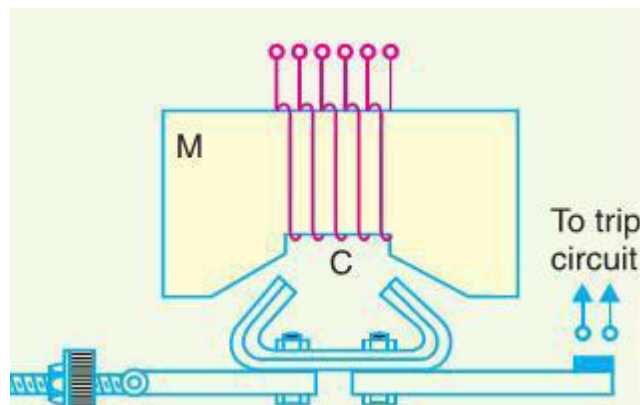

(ii) **Solenoid type relay.** Fig. 21.4 shows the schematic arrangement of a solenoid type relay. It consists of a solenoid and movable iron plunger arranged as shown. Under normal operating conditions, the current through the relay coil C is such that it holds the plunger by gravity or spring in the position shown. However, on the occurrence of a fault, the current through the relay coil becomes more than the pickup value, causing the plunger to be attracted to the solenoid. The upward movement of the plunger closes the trip circuit, thus opening the circuit breaker and disconnecting the faulty circuit.

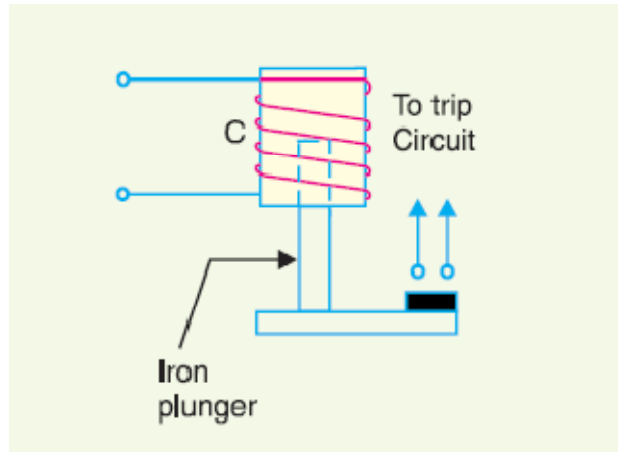

(iii) Balanced beam type relay. Fig. 21.5 shows the schematic arrangement of a balanced beam type relay. It consists of an iron armature fastened to a balance beam. Under normal operating conditions, the current through the relay coil is such that the beam is held in the horizontal position by the spring. However, when a fault occurs, the current through the relay coil becomes greater than the pickup value and the beam is attracted to close the trip circuit. This causes the opening of the circuit breaker to isolate the faulty circuit.

Induction Relays:

Electromagnetic induction relays operate on the principle of induction motor and are widely used for protective relaying purposes involving a.c. quantities. An induction relay essentially consists of a pivoted aluminum disc placed in two alternating magnetic fields of the same frequency but displaced in time and space. The torque is produced in the disc by the interaction of one of the magnetic fields with the currents induced in the disc by the other.

To understand the production of torque in an induction relay, refer to the elementary arrangement shown in Fig. below (i). The two A.C. fluxes ϕ_2 and ϕ_1 differing in phase by an angle α induce e.m.f.s' in the disc and cause the circulation of eddy currents I_2 and I_1 respectively. These currents lag behind their respective fluxes by 90°. Referring to Fig. below (ii) where the two A.C. fluxes and induced currents are shown separately for clarity let

$$\begin{aligned}\phi_1 &= \phi_{1max} \sin \omega t \\ \phi_2 &= \phi_{2max} \sin (\omega t + \alpha)\end{aligned}$$

Where ϕ_1 and ϕ_2 are the instantaneous values of fluxes and ϕ_2 leads ϕ_1 by an angle α .

Assuming that the paths in which the rotor currents flow have negligible self-inductance, the rotor currents will be in phase with their voltages.

When current flows in a wire, and an external magnetic field is applied across that flow, the wire experiences a force perpendicular both to that field and to the direction of the current flow. A left hand can be held, as shown in the illustration, so as to represent three mutually orthogonal axes on the thumb, first finger and middle finger.

Each finger is then assigned to a quantity (mechanical force, magnetic field and electric current). The right and left hand are used for generators and motors respectively.

$$i_1 \propto \frac{d\phi_1}{dt} \propto \frac{d}{dt} (\phi_{1max} \sin \omega t)$$

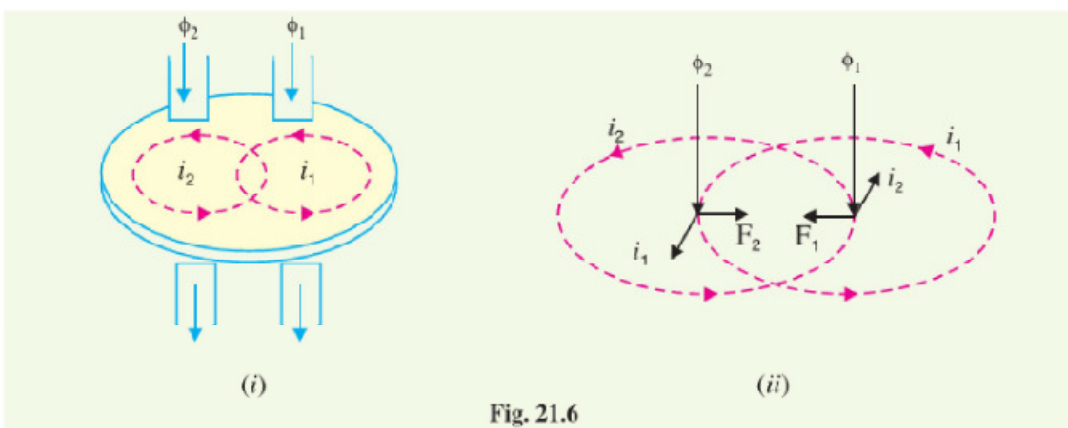

Fig. 21.6

$$\begin{aligned}\text{and} \quad & \propto \phi_{1max} \cos \omega t \\ & i_2 \propto \frac{d\phi_2}{dt} \propto \phi_{2max} \cos (\omega t + \alpha) \\ \text{Now,} \quad & F_1 \propto \phi_1 i_2 \quad \text{and} \quad F_2 \propto \phi_2 i_1\end{aligned}$$

Net force F at the instant considered is

$$\begin{aligned}
 F &\propto F_2 - F_1 \\
 &\propto \phi_2 i_1 - \phi_1 i_2 \\
 &\propto \phi_{2max} \sin(\omega t + \alpha) \phi_{1max} \cos \omega t - \phi_{1max} \sin \omega t \phi_{2max} \cos(\omega t + \alpha) \\
 &\propto \phi_{1max} \phi_{2max} [\sin(\omega t + \alpha) \cos \omega t - \sin \omega t \cos(\omega t + \alpha)] \\
 &\propto \phi_{1max} \phi_{2max} \sin \alpha \\
 &\propto \phi_1 \phi_2 \sin \alpha \quad \dots(i)
 \end{aligned}$$

The following points may be noted from exp. (i) :

- (a) The greater the phase angle α between the fluxes, the greater is the net force applied to the disc. Obviously, the maximum force will be produced when the two fluxes are 90° out of phase.
- (b) The net force is the same at every instant. This fact does not depend upon the assumptions made in arriving at exp. (i).
- (c) The direction of net force and hence the direction of motion of the disc depends upon which flux is leading.

The following three types of structures are commonly used for obtaining the phase difference in the fluxes and hence the operating torque in induction relays:

- (i) shaded-pole structure
- (ii) watt-hour-meter or double winding structure
- (iii) induction cup structure

(i) shaded-pole structure:

The general arrangement of shaded-pole structure is shown in Fig. below. It consists of a pivoted aluminum disc free to rotate in the air-gap of an electromagnet. One half of each pole of the magnet is surrounded by a copper band known as shading ring. The alternating flux ϕ_s in the shaded portion of the poles will, owing to the reaction of the current induced in the ring, lag behind the flux ϕ_u in the unshaded portion by an angle α . These two a.c. fluxes differing in phase will produce the necessary torque to rotate the disc. As proved earlier, the driving torque T is given by:

$$T \propto \phi_s \phi_u \sin \alpha$$

Assuming the fluxes ϕ_s and ϕ_u to be proportional to the current I in the relay coil,

$$T \propto I^2 \sin \alpha$$

This shows that driving torque is proportional to the square of current in the relay coil.

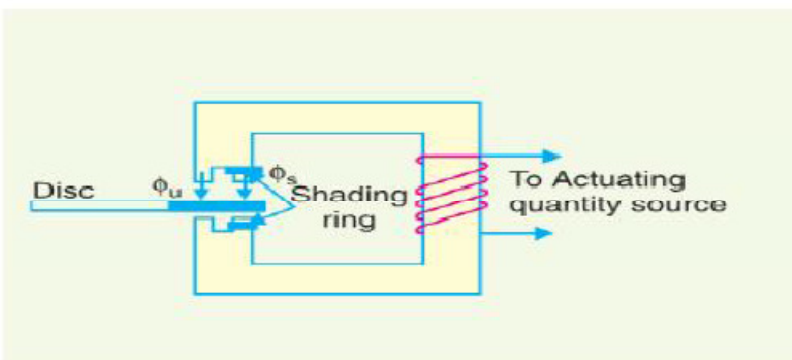

(ii) Watt-hour-meter structure. This structure gets its name from the fact that it is used in watt-hour meters. The general arrangement of this type of relay is shown in Fig. It consists of a pivoted aluminium disc arranged to

rotate freely between the poles of two electromagnets. The upper electromagnet carries two windings ; the primary and the secondary. The primary winding carries the relay current I_1 while the secondary winding is connected to the winding of the lower magnet. The primary current induces e.m.f. in the secondary and so circulates a current I_2 in it. The flux ϕ_2 induced in the lower magnet by the current in the secondary winding of the upper magnet will lag behind ϕ_1 by an angle α . The two fluxes ϕ_1 and ϕ_2 differing in phase by α will produce a driving torque on the disc proportional to $\phi_1 \phi_2 \sin \alpha$.

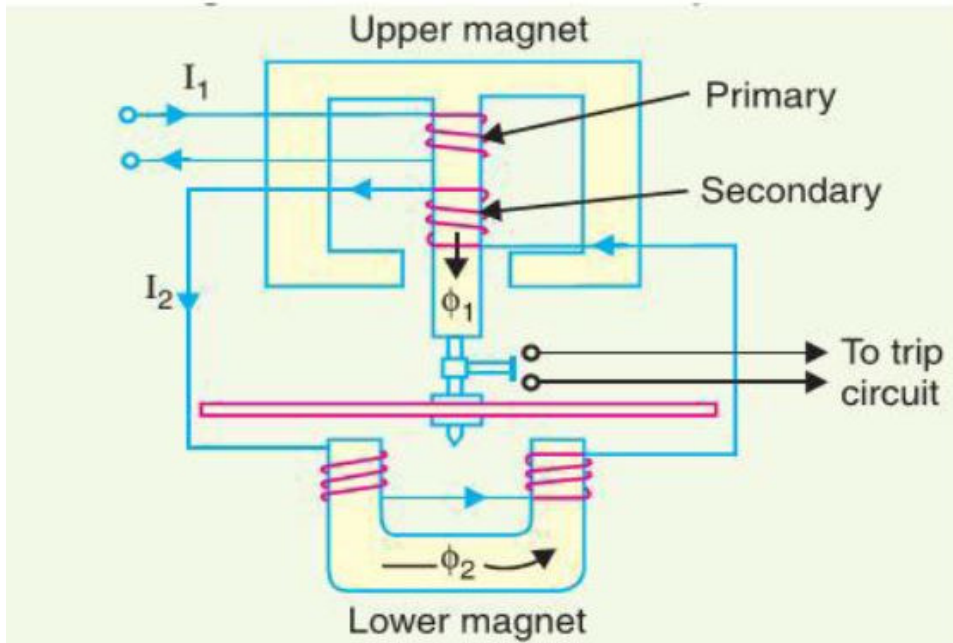

An important feature of this type of relay is that its operation can be controlled by opening or closing the secondary winding circuit. If this circuit is opened, no flux can be set by the lower magnet however great the value of current in the primary winding may be and consequently no torque will be produced. Therefore, the relay can be made inoperative by opening its secondary winding circuit.

(iii) Induction cup structure

Fig. shows the general arrangement of an induction cup structure. It most closely resembles an induction motor, except that the rotor iron is stationary, on the rotor conductor portion being free to rotate.

The moving element is a hollow cylindrical rotor which turns on its axis. The rotating field is produced by two pairs of coils wound on four poles as shown. The rotating field induces currents in the cup to provide the necessary driving torque. If ϕ_1 and ϕ_2 represent the fluxes produced by the respective pairs of poles, then torque produced is proportional to $\phi_1 \phi_2 \sin \alpha$ where α is the phase difference between the two fluxes. A control spring and the back stop for closing of the contacts carried on an arm are attached to the spindle of the cup to prevent the continuous rotation. Induction cup structures are more efficient torque producers than either the shaded-pole or the Watt-hour meter structures.

Therefore, this type of relay has very high speed and may have an operating time less than 0.1 second.

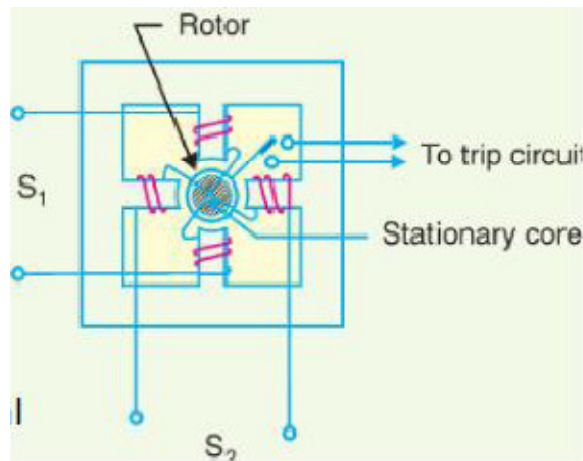

Relay timing:

An important characteristic of a relay is its time of operation. By 'the time of operation' is meant length of the time from the instant when the actuating element.

(i) Instantaneous relay:

An instantaneous relay is one in which no intentional time delay is provided. In this case, the relay contacts are closed immediately after current in the relay coil exceeds the minimum calibrated value. Fig. below shows an instantaneous solenoid type of relay. ment is energized to the instant when the relay contacts are closed. e.g. one-cycle would be 1/50 second in a 50-cycle system.

(ii) Inverse-time relay:

An inverse-time relay is one in which the operating time is approximately inversely proportional to the magnitude of the actuating quantity. Fig.shows the time-current characteristics of an inverse current relay.

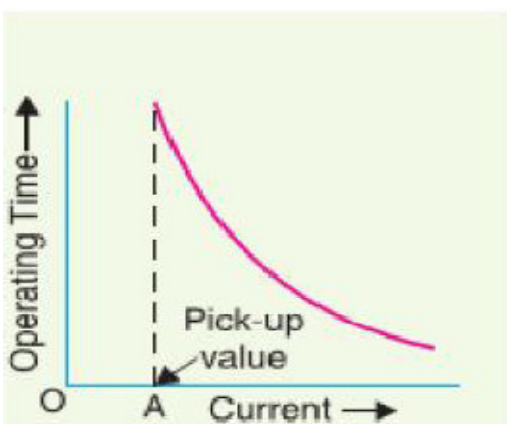

(a) In an induction relay, the inverse-time delay can be achieved by positioning a permanent magnet (known as a drag magnet) in such a way that relay disc cuts the flux between the poles of the magnet. When the disc moves, currents set up in it produce a drag on the disc which slows its motion.

(b) In other types of relays, the inverse time delay can be introduced by oil dashpot or a time limit fuse. Fig. previously shows an inverse time solenoid relay using oil dashpot. The piston in the oil dashpot attached to the

moving plunger slows its upward motion. At a current value just equal to the pickup, the plunger moves slowly and time delay is at a maximum. At higher values of relay current, the delay time is shortened due to greater pull on the plunger.

The inverse-time characteristic can also be obtained by connecting a time-limit fuse in parallel with the trip coil terminals as shown in previous fig, The shunt path formed by time-limit fuse is of negligible impedance as compared with the relatively high impedance of the trip coil. Therefore, so long as the fuse remains intact, it will divert practically the whole secondary current of CT from the trip oil. When the secondary current exceeds the current carrying capacity of the fuse, the fuse will blow and the whole current will pass through the trip coil, thus opening the circuit breaker.

(iii) Definite time lag relay:

In this type of relay, there is a definite time elapse between the instant of pickup and the closing of relay contacts. This particular time setting is independent of the amount of current through the relay coil ; being the same for all values of current in excess of the pickup value. It may be worthwhile to mention here that practically all inverse-time relays are also provided with definite minimum time feature in order that the relay may never become instantaneous in its action for very long overloads.

Important Terms

It is desirable to define and explain some important terms much used in connection with relays.

(i) Pick-up current. It is the minimum current in the relay coil at which the relay starts to operate. So long as the current in the relay is less than the pick-up value, the relay does not operate and the breaker controlled by it remains in the closed position.

However, when the relay coil current is equal to or greater than the pickup value, the relay operates to energize the trip coil which opens the circuit breaker.

(ii) Current setting. It is often desirable to adjust the pick-up current to any required value. This is known as current setting and is usually achieved by the use of tapping on the relay operating coil. The taps are brought out to a plug bridge as shown in Fig. below, the plug bridge permits to alter the number of turns on the relay coil. This changes the torque on the disc and hence the time of operation of the relay.

∴ Pick-up current = Rated secondary current of C.T. × Current setting

For example, suppose that an over current relay having current setting of 125% is connected to a supply circuit through a current transformer of 400/5. The rated secondary current of C.T. is 5 amperes. Therefore, the pick-up value will be 25% more than 5 A i.e. $5 \times 1.25 = 6.25$ A. It Means that with above current setting, the relay will actually operate for a relay coil current equal to or greater than 6.25 A.

Plug-setting multiplier (P.S.M.): It is the ratio of fault current in relay coil to the pick-up current.

For example, suppose that a relay is connected to a 400/5 current transformer and set at 150%. With a primary fault current of 2400 A, the plug-setting multiplier can be calculated as under:

Pick-up value = Rated secondary current of CT Current setting = $5 * 1.5 = 7.5$ A

Fault current in relay coil = $2400 \times 5 / 400 = 30$ A P.S.M = $30 / 7.5 = 4$

(iv) Time-setting multiplier. A relay is generally provided with control to adjust the time of operation. This adjustment is known as time-setting multiplier. The time-setting dial is calibrated from 0 to 1 in steps of 0.05 sec (see Fig. below).

These figures are multipliers to be used to convert the time derived from time/P.S.M. curve into the actual operating time. Thus if the time setting is 0.1 and the time obtained from the time/P.S.M. curve is 3 seconds, then actual relay operating time = $3 \times 0.1 = 0.3$ second. For instance, in an induction relay, the time of operation is controlled by adjusting the amount of travel of the disc from its reset position to its pickup position. This is achieved by the adjustment of the position of a movable backstop which controls the travel of the disc and thereby varies the time in which the relay will close its contacts for given values of fault current. A so-called "time dial" with an evenly divided scale provides this adjustment. The actual time of operation is calculated by multiplying the time setting multiplier with the time obtained from time/P.S.M. curve of the relay.

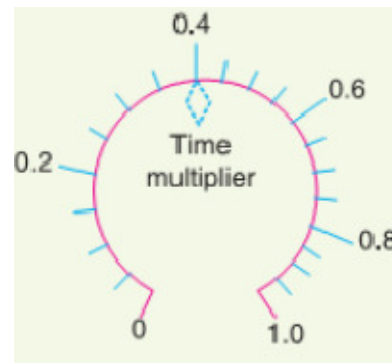

Functional Relay Types:

Most of the relays in service on power system today operate on the principle of electromagnetic attraction or electromagnetic induction. Regardless of the principle involved, relays are generally classified according to the function they are called upon to perform in the protection of electric power circuits.

For example, a relay which recognizes over current in a circuit (i.e. current greater than that which can be tolerated) and initiates corrective measures would be termed as an over current relay irrespective of the relay design. Similarly an overvoltage relay is one which recognizes overvoltage in a circuit and initiates the corrective measures. Although there are several types of special function relays, only the following important types will be discussed:

- (i) Induction type over current relays
- (ii) Induction type reverse power relays
- (iii) Distance relays
- (iv) Differential relays

Induction Type Directional Power Relay

This type of relay operates when power in the circuit flows in a specific direction. Unlike a non-directional over current relay, a directional power relay is so designed that it obtains its operating torque by the interaction of magnetic fields derived from both voltage and current source of the circuit it protects.

Thus this type of relay is essentially a wattmeter and the direction of the torque set up in the relay depends upon the direction of the current relative to the voltage with which it is associated. Constructional details Fig. below shows the essential parts of a typical induction type directional power relay.

It consists of an aluminum disc which is free to rotate in between the poles of two electromagnets. The upper electromagnet carries a winding (called potential coil) on the central limb which is connected through a potential transformer (P.T.) to the circuit voltage source.

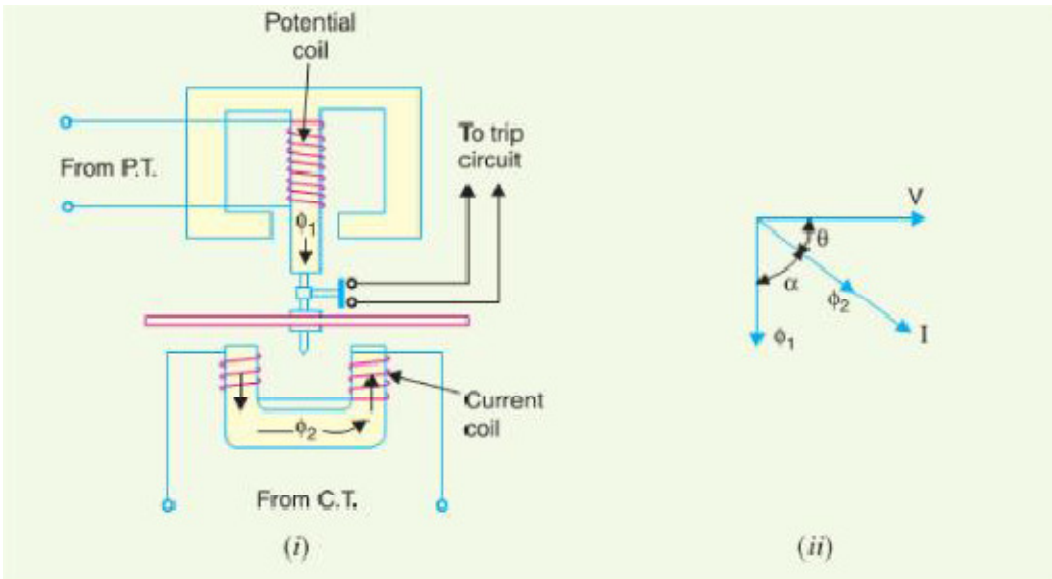

The lower electromagnet has a separate winding (called current coil) connected to the secondary of C.T. in the line to be protected. The current coil is provided with a number of tappings connected to the plug setting bridge (not shown for clarity).

This permits to have any desired current setting.

The restraining torque is provided by a spiral spring. The spindle of the disc carries a moving contact which bridges two fixed contacts when the disc has rotated through a pre-set angle. By adjusting this angle, the travel of the moving disc can be adjusted and hence any desired time-setting can be given to the relay.

Operation: The flux ϕ_1 due to current in the potential coil will be nearly 90° lagging behind the applied voltage V . The flux ϕ_2 due to current coil will be nearly in phase with the operating current I [See vector diagram in fig.]. The interaction of fluxes ϕ_1 and ϕ_2 with the eddy currents induced in the disc produces a driving torque given by :

$$T \propto \phi_1 \phi_2 \sin \alpha$$

Since $\phi_1 \propto V$, $\phi_2 \propto I$ and $\alpha = 90 - \theta$

$$T \propto V I \sin (90 - \theta)$$

$$\propto V I \cos \theta$$

$$\propto \text{power in the circuit}$$

It is clear that the direction of driving torque on the disc depends upon the direction of power flow in the circuit to which the relay is associated. When the power in the circuit flows in the normal Direction, the driving torque and the restraining torque (due to spring) help each other to turn away the moving contact from the fixed contacts. Consequently, the relay remains inoperative. However, the reversal of current in the circuit reverses the direction of driving torque on the disc. When the reversed driving torque is large enough, the disc rotates in the reverse direction and the moving contact closes the trip circuit. This causes the operation of the circuit breaker which disconnects the faulty section.

Induction Type Directional Over current Relay:

The directional power relay discussed above is unsuitable for use as a directional protective relay under short-circuit conditions. When a short circuit occurs, the system voltage falls to a low value and there may be insufficient torque developed in the relay to cause its operation. This difficulty is overcome in the directional over current relay which is designed to be almost independent of system voltage and power factor.

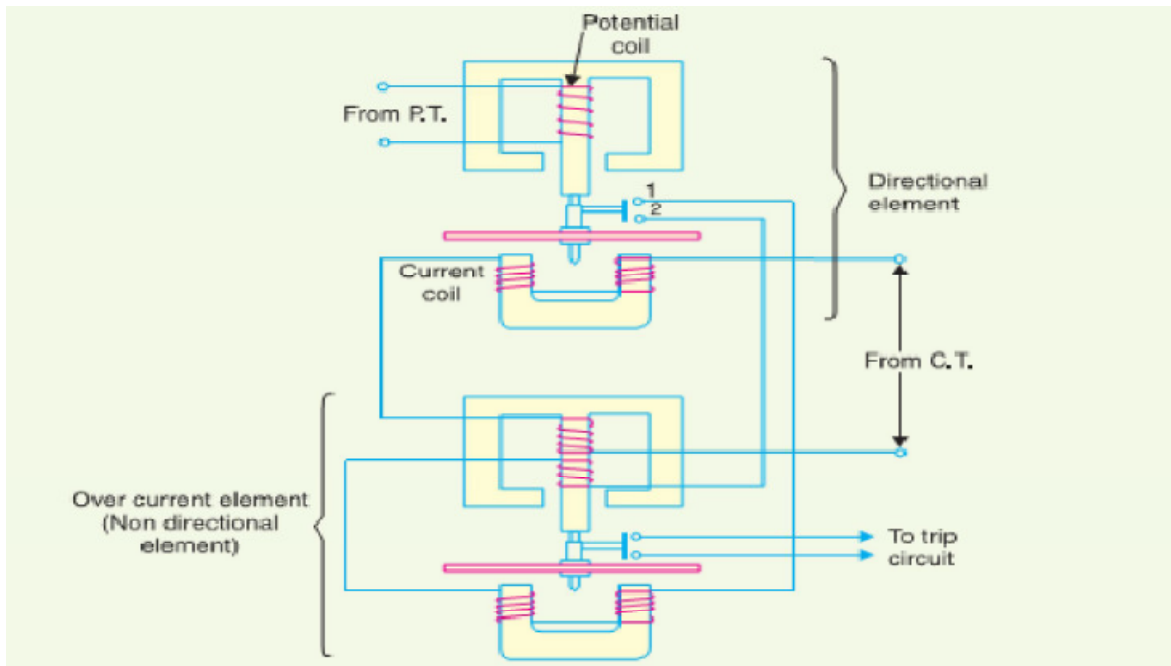

Constructional details:

Fig. Shows the constructional details of a typical induction type directional over current relay. It consists of two relay elements mounted on a common case viz.(i)directional element and (ii) non-directional element.

(i) Directional element. It is essentially a directional power relay which operates when power flows in a specific direction. The potential coil of this element is connected through a potential transformer (P.T.) to the system voltage.

(ii) Non-directional element. It is an Over current element similar in all respects to a non-directional over current relay.

Operation:

Under normal operating conditions, power flows in the normal direction in the circuit protected by the relay. Therefore, directional power relay (upper element) does not operate, thereby keeping the over current element

(lower element) un-energized. However, when a short-circuit occurs, there is a tendency for the current or power to flow in the reverse direction. Should this happen, the disc of the upper element rotates to bridge the fixed contacts 1 and 2. This completes the circuit for over current element. The disc of this element rotates and the moving contact attached to it closes the trip circuit. This operates the circuit breaker which isolates the faulty section.

The two relay elements are so arranged that final tripping of the current controlled by them is not made till the following conditions are satisfied:

- (i) Current flows in a direction such as to operate the directional element.
- (ii) Current in the reverse direction exceeds the pre-set value.
- (iii) Excessive current persists for a period corresponding to the time setting of over current element.

Differential Relays:

Most of the relays discussed so far relied on excess of current for their operation. Such relays are less sensitive because they cannot make correct distinction between heavy load conditions and minor fault conditions. In order to overcome this difficulty, differential relays are used.

A **differential relay** is one that operates when the phasor difference of two or more similar electrical quantities exceeds a pre-determined value.

Thus a current differential relay is one that compares the current entering a section of the system with the current leaving the section. Under normal operating conditions, the two currents are equal but as soon as a fault occurs, this condition no longer applies. The difference between the incoming and outgoing currents is arranged to flow through the operating coil of the relay. If this differential current is equal to or greater than the pickup value, the relay will operate and open the circuit breaker to isolate the faulty section.

It may be noted that almost any type of relay when connected in a particular way can be made to operate as a differential relay. In other words, it is not so much the relay construction as the way the relay is connected in a circuit that makes it a differential relay. There are two fundamental systems of differential or balanced protection viz.

- (i) Current balance protection
- (ii) Voltage balance protection

Current Differential Relay

Fig. shows an arrangement of an overcurrent relay connected to operate as a differential relay. A pair of identical current transformers is fitted on either end of the section to be protected (alternator winding in this case). The secondaries of CT's are connected in series in such a way that they carry the induced currents in the same direction. The operating coil of the over current relay is connected across the CT secondary circuit. This differential relay compares the current at the two ends of the alternator winding

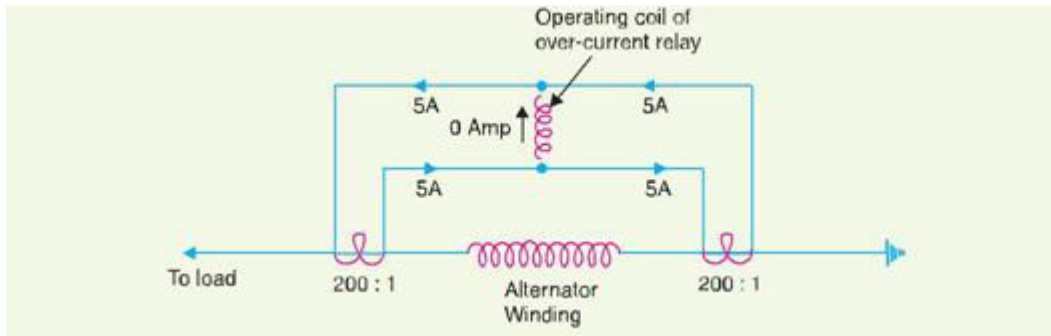

Under normal operating conditions, suppose the alternator winding carries a normal current of 1000 A. Then the currents in the two secondaries of CT's are equal [See Fig.].

These currents will merely circulate between the two CT's and no current will flow through the differential relay. Therefore, the relay remains inoperative. If a ground fault occurs on the alternator winding as shown in Fig. (i), the two secondary currents will not be equal and the current flows through the operating coil of the relay, causing the relay to operate. The amount of current flow through the relay will depend upon the way the fault is being fed.

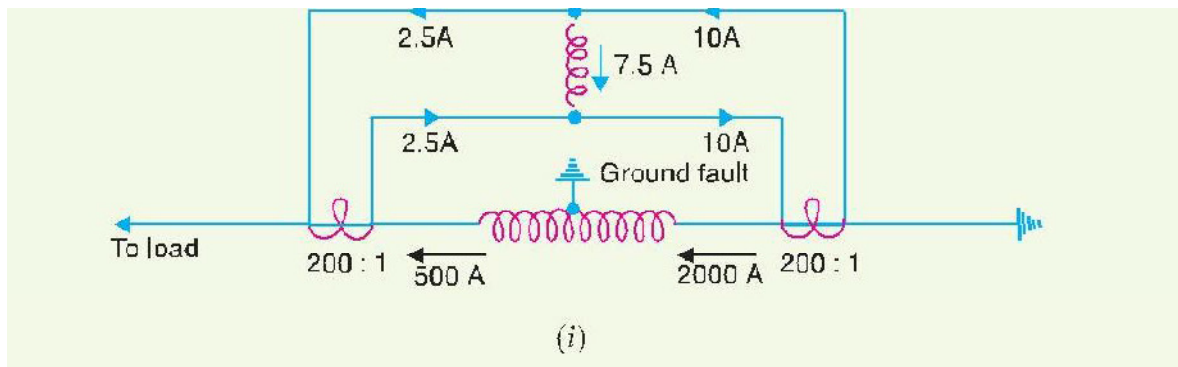

Disadvantages

(i) The impedance of the pilot cables generally causes a slight difference between the currents at the two ends of the section to be protected. If the relay is very sensitive, then the small differential current flowing through the relay may cause it to operate even under no fault conditions.

(ii) Pilot cable capacitance causes incorrect operation of the relay when a large through-current flows.

(iii) Accurate matching of current transformers cannot be achieved due to pilot circuit impedance.

The above disadvantages are overcome to a great extent in biased beam relay.

Distance Relays:

Distance protection is the protection and High Voltage (HV) and Extra High Voltage (EHV) transmission lines. It employs a number of distance relays. Each distance relay measures the impedance of the line from the fault point to the location of relay. Since the impedance is proportional to the line-length which in turn depends on the distance, the relay is called distance relay.

The distance protection provides both primary and back-up protection. Various types of distance relays are

- i. Impedance Relay
- ii. Reactance Relay
- iii. MHO Relay
- iv. Quadrilateral Relay
- v. Elliptical Relays
- vi. Angle impedance Relays

Here we discuss only first three types of relays.

3.6. IMPEDANCE RELAY:

An Impedance relay measures the impedance of the line from fault point to the point of location of relay. This impedance is proportional to the distance of the relay from the fault point. Impedance includes both resistance and reactance.

Operating Principle:

The Operating torque of an electromagnetic impedance relay is the sum of torques due to current, voltage and control-spring. Current produces operating torque (positive) and voltage produces restraining torque (negative).

$$\therefore \tau = K_1 I^2 - K_2 V^2 - K_3$$

where K_1 , K_2 and K_3 are constants.

Since K_3 is very small, it is neglected

$$\tau = K_1 I^2 - K_2 V^2$$

For the relay to operate

Operating torque > restraining torque

$$\therefore K_1 I^2 > K_2 V^2$$

$$\Rightarrow \frac{V^2}{I^2} < \frac{K_1}{K_2}$$

$$\Rightarrow \frac{V}{I} < K$$

$$\Rightarrow Z < K \quad \text{--- (1)}$$

For static or micro processor based impedance relays

$$K_1 I > K_2 V$$

$$\Rightarrow \frac{V}{I} < K$$

$$\Rightarrow Z < K \quad \text{--- (2)}$$

From both equation (1) and (2),

We can say that the relay operates only when the measured impedance is less than the given constant.

Characteristics:

The $V-I$ characteristics of impedance relay is shown in the graph drawn below.

Figure 3.12

$$Z = \frac{K_1}{K_2} \cos(\theta - \tau)$$

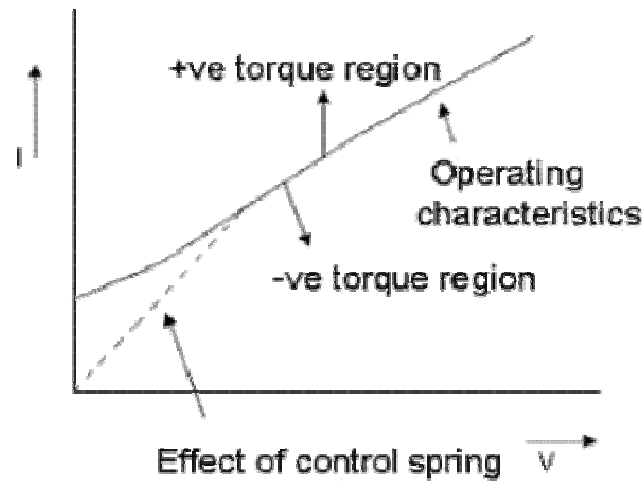

The graph is bent slightly at origin in electromagnetic relay due to the effect of control spring. For static and micro processor based relays the characteristics is a straight line.

Another way of representation of characteristics is by R - X diagram, as shown in the figure drawn below.

Figure 3.13

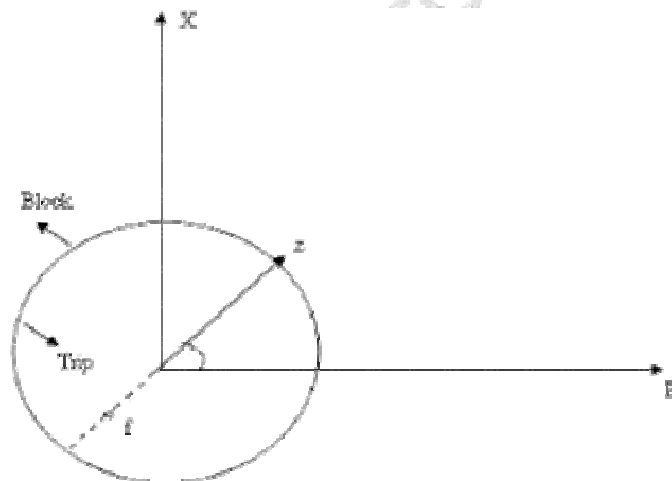

The circle shown in the above figure represents $z = k$ and outside the circle $z > k$ and inside the circle $z < k$. Φ is the phase angle between V and I . The operation of relay does not depend on Φ but depends only on the value of z . k is equal to the impedance of the line to be protected. If value of z is less than k it means fault point lies in the zone of relay and the relay operates and sends a trip signal. If value of z is greater than k , then the relay does not operate and it is in block mode i.e. fault point does not lie in zone of operation.

Directional unit used with impedance relay:

An impedance relay without directional relay operates when the fault is in any direction i.e. either forward or backward. But when directional unit is used, the relay is

made to operate only when the fault is in specified direction. At any location, three impedance relays and a directional relay is employed. Directional relay is connected in series with the three impedance relay is shown in the figure drawn below.

Figure 3.14

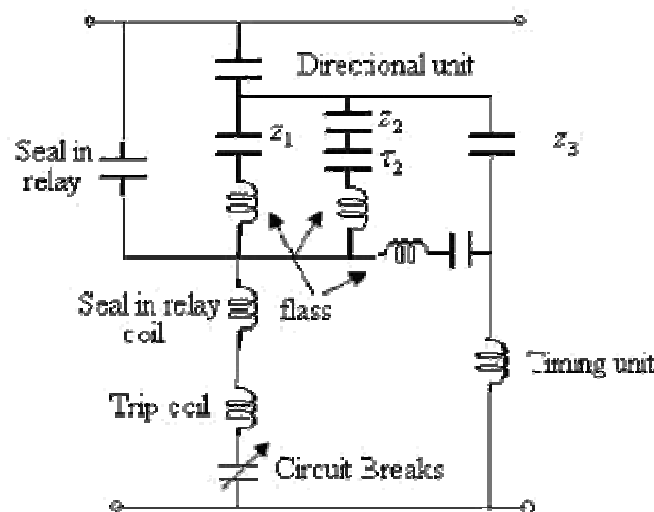

τ_2 and τ_3 are the contacts of the timer for the second and third units. The characteristics of three-zone impedance relay with directional unit are shown in figure drawn below.

Figure 3.15

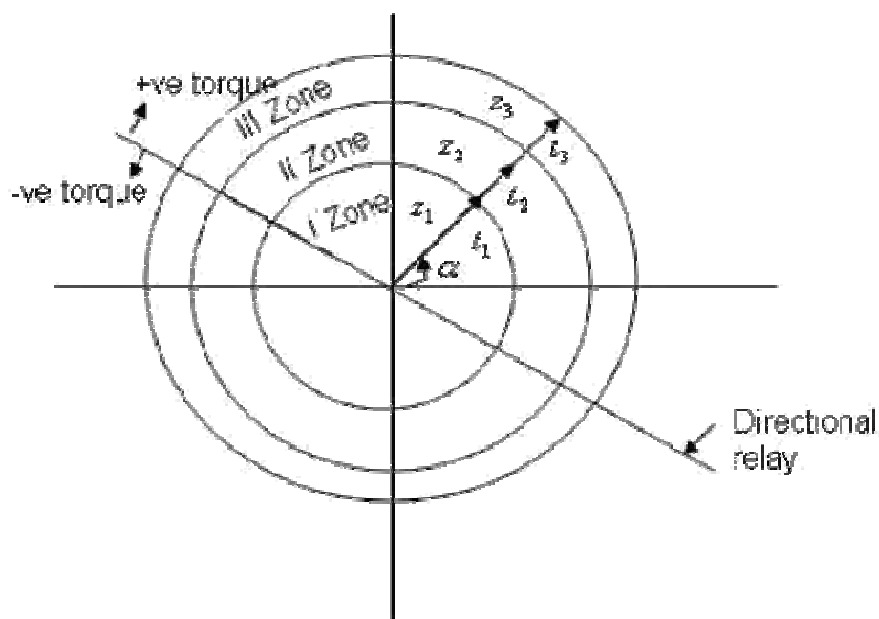

The characteristic circle is z_1 is smaller, z_2 is medium and z_3 is larger. t_1 , t_2 and t_3 are operating time for three relays.

The characteristic circle is z_1 is smaller, z_2 is medium and z_3 is larger. t_1 , t_2 and t_3 are operating time for three relays.

When a fault lies within small circle and in the region of directional relay, the z_1 operates at a time t_1 . When the fault lies outside z_1 but inside z_2 , then T_2 closes after time t_2 when the circuit breaker trips. If the fault lies inside z_3 but outside z_1 and z_2 , the circuit breaker trips after closure of contact T_3 at time t_3 . The circuit breaker auxiliary switch is a

normally closed switch. When the circuit breaker trips, the auxiliary switch is opened to prevent damage of battery. A seal in relay is used to protect of contacts of main relay.

Reactance Relay:

Similar to the impedance relay, reactance relay measures the reactance of the line between the relay location and fault point. The operation of this relay is independent of resistance but depends only on reactance of line.

Hence the operating characteristics of reactance relay on R-X diagram is a straight line parallel to R-axis as shown in the figure drawn below.

Figure 3.16

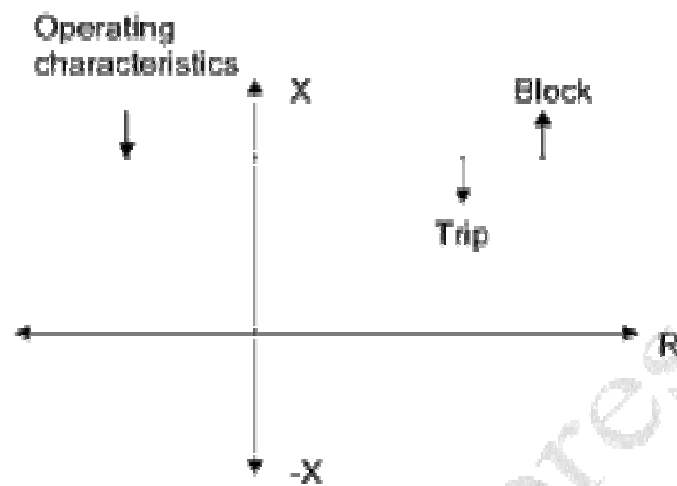

Induction – cup type reactance relay:

The figure drawn below shows Induction cup type reactance relay. The current produces polarizing flux in the upper, lower and right hand side poles. The flux in right hand side pole is out of phase with that of upper and lower poles due to its secondary winding closed through a phase shifting network.

The actuating quantity for left hand side pole is voltage through a phase shifting circuit.

Therefore the polarizing flux interacts with right hand side pole to develop torque $K_1 I^2$ (operating torque) and the flux interacts with left hand side pole to develop torque $K_2 V \cos(90^\circ - \Phi)$.

Therefore the total torque is given by $\tau = K_1 I^2 - K_2 V \cos(90^\circ - \Phi) - K_3$

Where K_3 is due to control spring.

For the relay to operate

Operating torque > Restraining torque

$$\therefore K_1 I^2 > K_2 V \cos(90^\circ - \Phi)$$

$$K_1 I > K_2 V \sin \Phi$$

$$\therefore \frac{V}{I} \sin \Phi < \frac{K_1}{K_2}$$

$$\therefore Z \sin \Phi < E$$

$$\Rightarrow X < K$$

Therefore the relay operates only when the reactance is less than a given constant

The connections for a reactance relay using directional unit is shown in the figure drawn below.

Figure 3.17

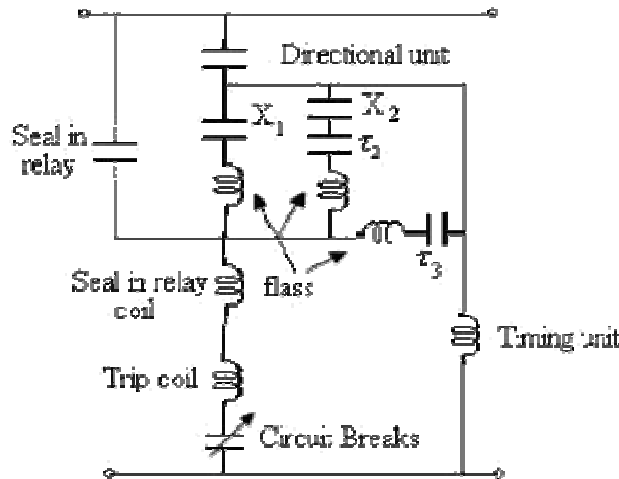

The characteristics diagram for the above reactance relay is shown below.

Figure 3.18

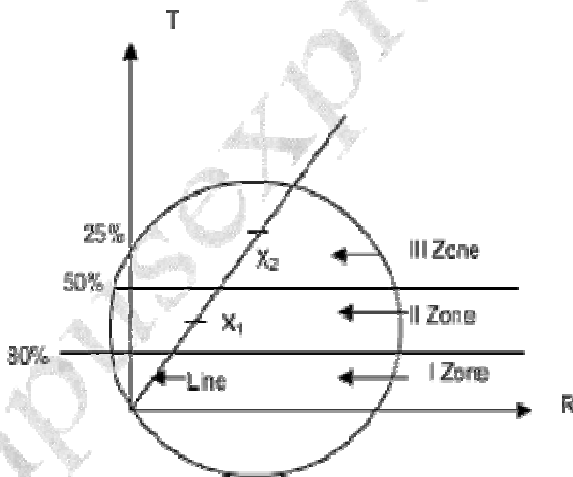

The circle represents the operating characteristics of directional unit. The unit I is used to protect 80 – 90% of the protected line. Unit II is used to protect 50% of the adjacent line. Unit III is a back – up protection for the whole adjacent line.

MHO Relay:

A MHO Relay or angle admittance relay measures a component of admittance $|y| \cos \theta$. It is a directional relay. The operating characteristics of MHO relay is a circle passing through origin when plotted in R-X diagram. When plotted in admittance diagram (G-B axes), its characteristics is a straight line.

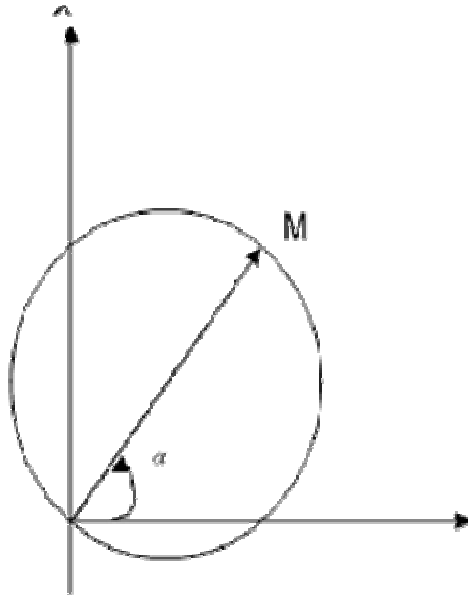

Electro magnetic MHO relay:

Electro magnetic induction cup type MHO relay is shown in the figure drawn below.

Figure 3.19

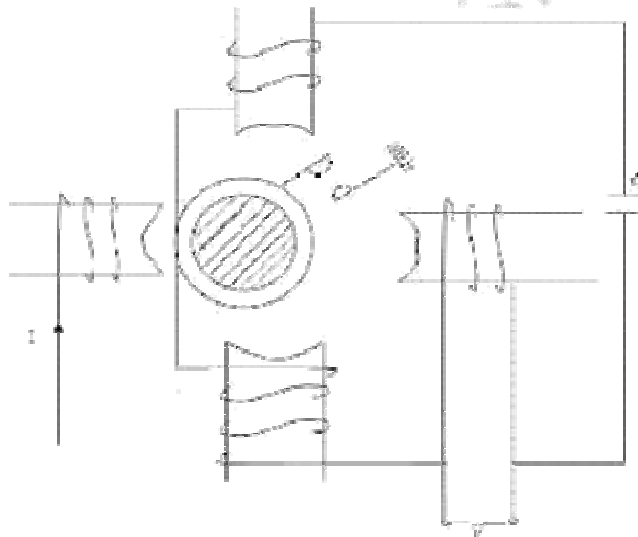

The upper and lower poles are energized by voltage. The left hand side pole is energized by actuating quantity current. The flux produced interacts with the polarizing flux to develop a torque $K_1 VI \cos(\Phi - \alpha)$ which is operating torque. The right hand side pole is energized by voltage V . The flux produced in right hand side pole interacts with the polarizing flux to develop restraining torque $K_2 V^2$. There fore the net torque is

$$\tau = K_1 VI \cos(\Phi - \alpha) - K_2 V^2 - K_3$$

Where K_3 is torque due to control spring.

For the relay to operate

Operating torque > Restraining torque

$$\therefore K_1 VI \cos(\Phi - \alpha) > K_2 V^2$$

$$(I/V) \cos(\Phi - \alpha) > (K_2/K_1)$$

$$Y \cos(\Phi - \alpha) > K$$

$$\frac{1}{Y \cos(\Phi - \alpha)} < K$$

$$M < K$$

\therefore The relay operates when M is less than a given constant.

The connection of MHO relay with three units is shown in the figure drawn below.

Figure 3.20

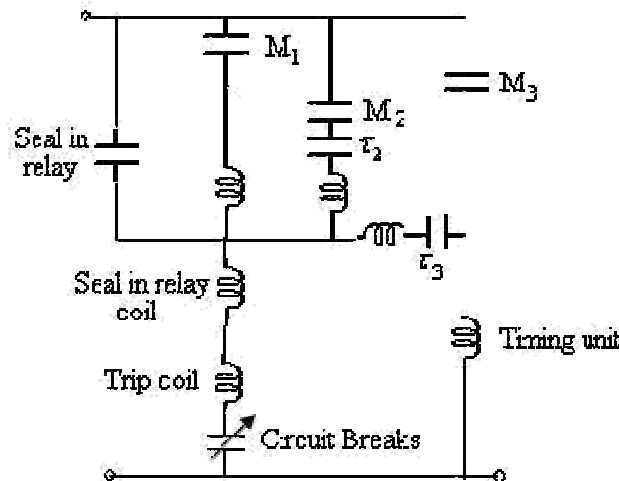

The operating characteristics for the above connection are shown in the figure drawn below.

Figure 3.21

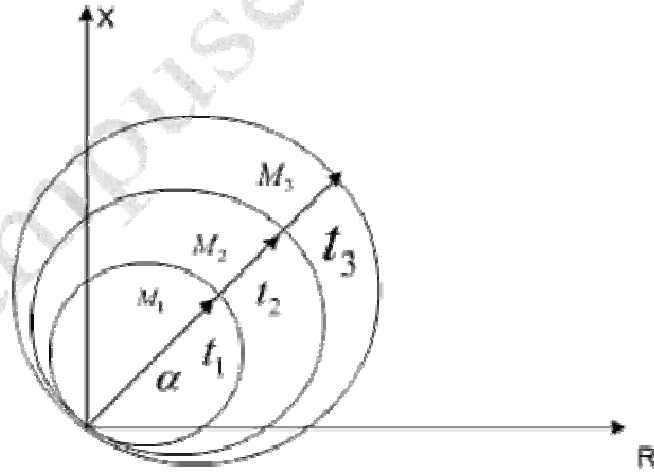

Unit I protects 80-90% of the protected section. Unit II protects 50% of the adjacent section. Unit III provides back-up protection.

Offset MHO Relay:

Offset MHO Relay can be realized using static MHO relay which is shown in figure below.

Figure 3.22

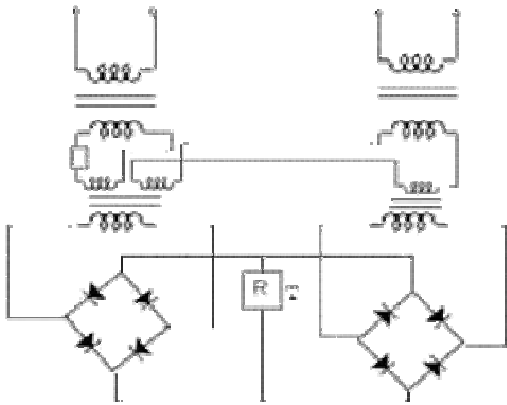

Here one actuating quantity is I (operating) and the other is $[(V/z_c) - nI]$ (restraining). Here n represents a fraction out put current of C.T is given to restrained circuit.

The relay operates only when

Operating quantity > Restraining quantity.

$$I > \left| \frac{V}{z_c} - nI \right|$$

Multiplying by z_c

$$|I z_c| > |V - nI z_c|$$

Dividing by z

$$|z_c| > \left| \frac{V}{I} - n z_c \right|$$

$$\Rightarrow |z_c| > |z - n z_c|$$

Therefore the characteristics of offset MHO relay is shown below.

Figure 3.23

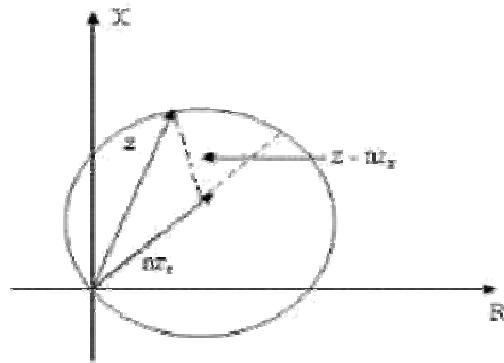

The typical offset value is 10% of protected line. When $V = 0$

$$I > |I - nI|$$

Since n is a fraction. So the relay operates.

The offset characteristics of 3 unit relay is shown in the figure where unit III is offset MHO relay.

Figure 3.24

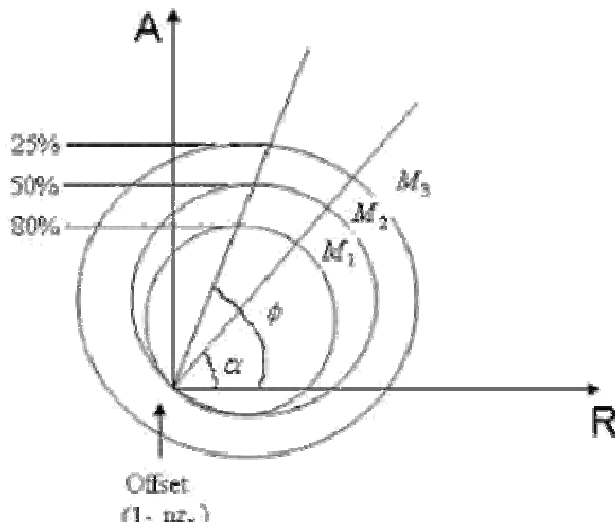

Notice that the characteristics of offset relay M_3 does not pass through origin. Unit III has following applications.

- i. Busbar zone back-up
- ii. Carrier starting unit
- iii. Power swing blocking

Comparison of characteristics of Distance Relay:

Impedance Relay:

Impedance relay is slightly affected by arc resistance as well as power and voltage surges. But it fails to detect a fault within 80% of protected line. Hence it is extensively used for medium lines for phase fault relay.

Reactance Relay:

Reactance relay is less affected by arc resistance and hence it is mainly used for ground fault relaying. It is also suitable for protection of short lines against phase faults. The main disadvantage of MHO relay is it is affected by power surges. So they are not suitable for longer lines since in long lines, power surges stays for a longer period.

MHO Relay:

MHO relay is less affected by power surges. MHO characteristics are best suited for protection of long lines against phase faults. But it is most affected by arc resistance.

3.7 STATIC RELAYS:

Static relay compares two electrical quantities using a static circuit and sends a tripping signal to the circuit breaker. The static circuit includes semiconductor diodes, transistors, thyristors, logic gates, diodes etc., static relays uses electromagnetic or dc polarized relays as slave relays. Slave relay do not actually measure the electrical quantity but it simply closed contact.

Static relays verses electromagnetic relays:

The advantages of static relays over electromagnetic are as follows:

1. Static relay is compact in size
2. Less maintenance is required
3. High resistance to shocks
4. Static relays consume less power. So it provides fewer burdens of potential transformers and current transformers.
5. There are no moving contacts.
6. A single static relay is used for several functions.
7. A static relay employs logic circuits. So it can do the process of reasoning.
8. It is used for remote back-up and network monitoring.

But the limitations of static relays are

1. The price of static relays is higher than the electromagnetic relays.
2. The device in the static circuit is very much affected by temperature.
3. Static devices such as thyristors are sensitive electro-static discharges (ESD).
4. The semi conductor devices are sensitive to voltage transients. So they may get damaged.

Protection of Alternators, Transformers, Busbars and Feeders

Module-III

Protection of Alternators

The generating units, especially the larger ones, are relatively few in number and higher in individual cost than most other equipments. Therefore, it is desirable and necessary to provide protection to cover the wide range of faults which may occur in the modern generating plant.

Some of the important faults which may occur on an alternator are :

- (i) failure of prime-mover
- (ii) failure of field
- (iii) overcurrent
- (iv) overspeed
- (v) overvoltage
- (vi) loading
- (vii) stator winding faults

(i) **Failure of prime-mover.** When input to the prime-mover fails, the alternator runs as a synchronous motor and draws some current from the supply system. This motoring conditions is known as —inverted runningl.

(a) In case of turbo-alternator sets, failure of steam supply may cause inverted running. If the steam supply is gradually restored, the alternator will pick up load without disturb-ing the system. If the steam failure is likely to be prolonged, the machine can be safely isolated by the control room attendant since this condition is relatively harmless. There-fore, automa-tic protection is not required.

(b) In case of hydro-generator sets, protection against inverted running is achieved by pro-viding mechanical devices on the water-wheel. When the water flow drops to an insuf-ficient rate to maintain the electrical output, the alternator is disconnected from the system. Therefore, in this case also electrical protection is not necessary.

(c) Diesel engine driven alternators, when running inverted, draw a considerable amount of power from the supply system and it is a usual practice to provide protection against motoring in order to avoid damage due to possible mechanical seizure. This is achieved by applying reverse power relays to the alternators which *isolate the latter during their motoring action. It is essential that the reverse power relays have time-delay in opera-tion in order to prevent inadvertent tripping during system disturbances caused by faulty synchronising and phase swinging.

(ii) **Failure of field.** The chances of field failure of alternators are undoubtedly very rare. Even if it does occur, no immediate damage will be caused by permitting the alternator to run without a field for a short-period. It is sufficient to rely on the control room attendant to disconnect the faulty alternator manually from the system bus-bars. Therefore, it is a uni-versal practice not to provide †automatic protection against this contingency.

(iii) **Overcurrent.** It occurs mainly due to partial breakdown of winding insulation or due to overload on the supply system. Overcurrent protection for alternators is considered unnec-essary because of the following reasons :

(a) The modern tendency is to design alternators with very high values of internal imped-ance so that they will stand a complete short-circuit at their terminals for sufficient time without serious overheating. On the occurrence of an overload, the alternators can be disconnected manually.

(b) The disadvantage of using overload protection for alternators is that such a protection might disconnect the alternators from the power plant bus on account of some momen-tary troubles outside the plant and, therefore, interfere with the continuity of electric service

(iv) **Overspeed.** The chief cause of overspeed is the sudden loss of all or the major part of load on the alternator. Modern alternators are usually provided with mechanical centrifugal devices mounted on their driving shafts to trip the main valve of the prime-mover when a dangerous overspeed occurs.

(v) **Over-voltage.** The field excitation system of modern alternators is so designed that over-voltage conditions at normal running speeds cannot occur. However, overvoltage in an alternator occurs when speed of the prime-mover increases due to sudden loss of the alternator load.

In case of steam-turbine driven alternators, the control governors are very sensitive to speed variations. They exercise a continuous check on overspeed and thus prevent the occurrence of over-voltage on the generating unit. Therefore, over-voltage protection is not provided on turbo-alternator sets.

In case of hydro-generator, the control governors are much less sensitive and an appreciable time may elapse before the rise in speed due to loss of load is checked. The over-voltage during this time may reach a value which would over-stress the stator windings and insulation breakdown may occur. It is, therefore, a usual practice to provide over-voltage protection on hydro-generator units. The over-voltage relays are operated from a voltage supply derived from the generator terminals. The relays are so arranged that when the generated voltage rises 20% above the normal value, they operate to

- (a) trip the main circuit breaker to disconnect the faulty alternator from the system
- (b) disconnect the alternator field circuit

(vi) **Unbalanced loading.** Unbalanced loading means that there are different phase currents in the alternator. Unbalanced loading arises from faults to earth or faults between phases on the circuit external to the alternator. The unbalanced currents, if allowed to persist, may either severely burn the mechanical fixings of the rotor core or damage the field winding.

Fig. 22.1 shows the schematic arrangement for the protection of alternator against unbalanced loading. The scheme comprises three line current transformers, one mounted in each phase, having their secondaries connected in parallel. A relay is connected in parallel across the transformer secondaries.

Under normal operating conditions, equal currents flow through the different

phases of the alternator and their algebraic sum is zero.

Therefore, the sum of the currents flowing in the secondaries

is also zero and no current flows through the

operating coil of the relay. However, if un-

balancing occurs, the currents induced in the secondaries will be different and t

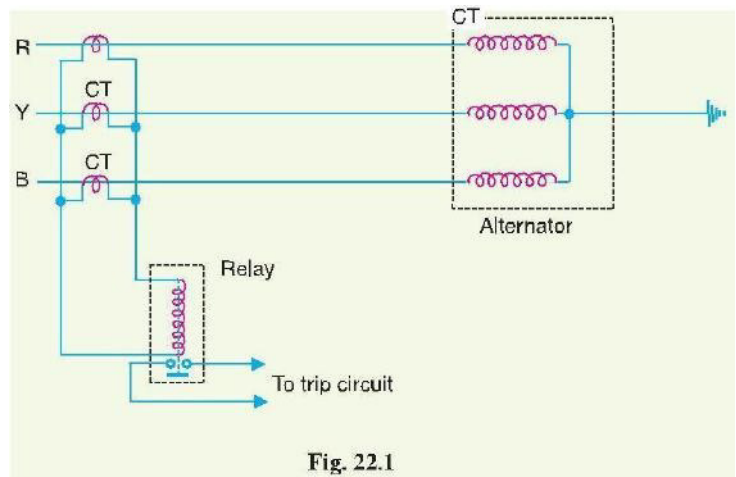

Fig. 22.1

resultant of these currents will flow through the relay. The operation of the relay will trip the circuit breaker to disconnect the alternator from the system.

(vii) Stator winding faults. These faults occur mainly due to the insulation failure of the stator windings. The main types of stator winding faults, in order of importance are :

- (a)** fault between phase and ground
- (b)** fault between phases
- (c)** inter-turn fault involving turns of the same phase winding

The stator winding faults are the most dangerous and are likely to cause considerable damage to the expensive machinery. Therefore, automatic protection is absolutely necessary to clear such faults in the quickest possible time in order to minimise the *extent of damage. For protection of alternators against such faults, differential method of protection is most commonly employed due to its greater sensitivity and reliability. This system of protection is discussed in the following section.

Merz-price Differential protection:

In merz-price differential protection the primaries of the CTs are connected in series on the both side of each phase winding of the generator. The secondaries of the CTs are connected in additive manner to pass the circulating currents through a closed path. The differential relay constantly checks on the secondary sides of CTs as to whether the incoming current of a phase winding is equal to the respective outgoing current of the same winding.

The directions of currents passing through the secondary side of the CTs are shown in fig. If the currents on the primary sides, that is, I_{A1} and I_{A2} , have the same magnitude, then the secondary side currents, i_{a1} and i_{a2} will also have the same magnitude, considering that CTs on both sides have same turns ratio and have identical characteristics. If there is a significant difference in currents (I_d) on both sides of the windings, then this indicates a fault in the protection zone of the stator winding of the generator. Hence the differential relay trips if the value of I_d exceeds a predetermined value (relay setting). On the other hand, during external faults, the differential relay remains stable and does not initiate a trip signal.

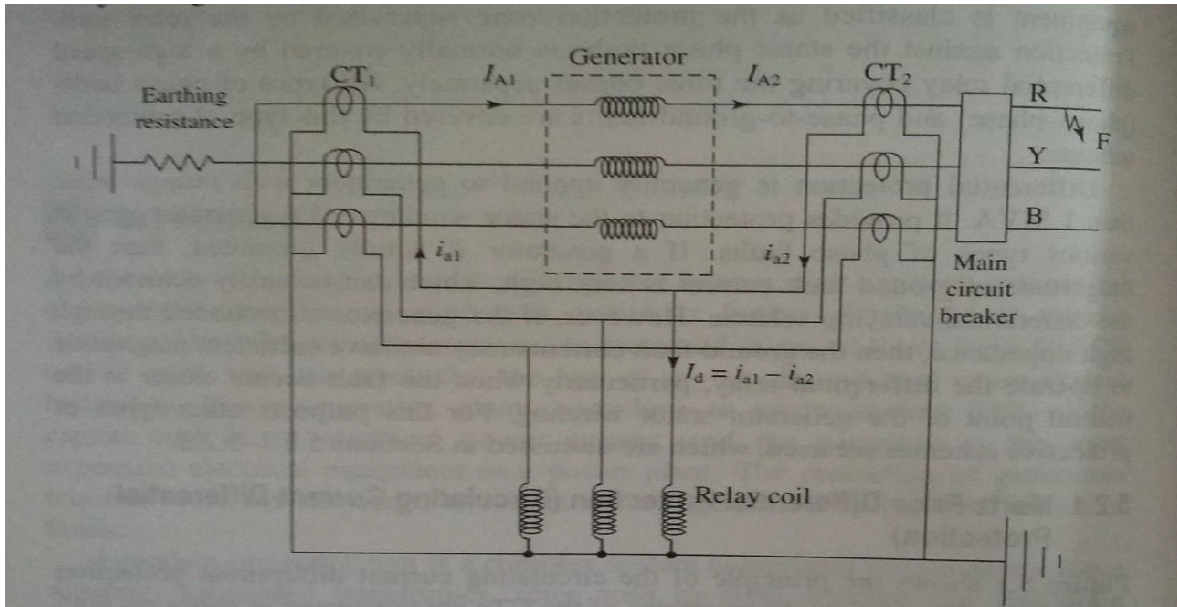

If the CTs are identical in nature, then the functioning the differential relay is straightforward. However, in practice, it is impossible to achieve CTs with identical saturation characteristics. Hence, the secondary currents of the CTs are unequal even though the primary currents are same. This current widely known as spill current. This spill current passes through the relay and may mal-operate the relay if the value exceeds the setting of the relay. This is possible particularly in case of heavy through fault conditions. Moreover, if the length of the connecting wires (pilot wires) is unequal, then the value of the spill current increases. In order to avoid mal-operation of the differential relay in those situations, a stabilizing resistance is connected in series with the relay. However, incorporation of the stabilizing resistance reduces the sensitivity of the relay during an internal fault.

Biased Differential Protection:

The main drawback of Merz-price differential protection is the reduction in sensitivity of the relay due to the incorporation of the stabilising resistance. Hence, to minimise this effect and also to increase the sensitivity of the differential relay, biased differential protection scheme is used. Fig shows the principle of the biased percentage differential scheme where no additional stabilizing resistance is connected in series with the relay.

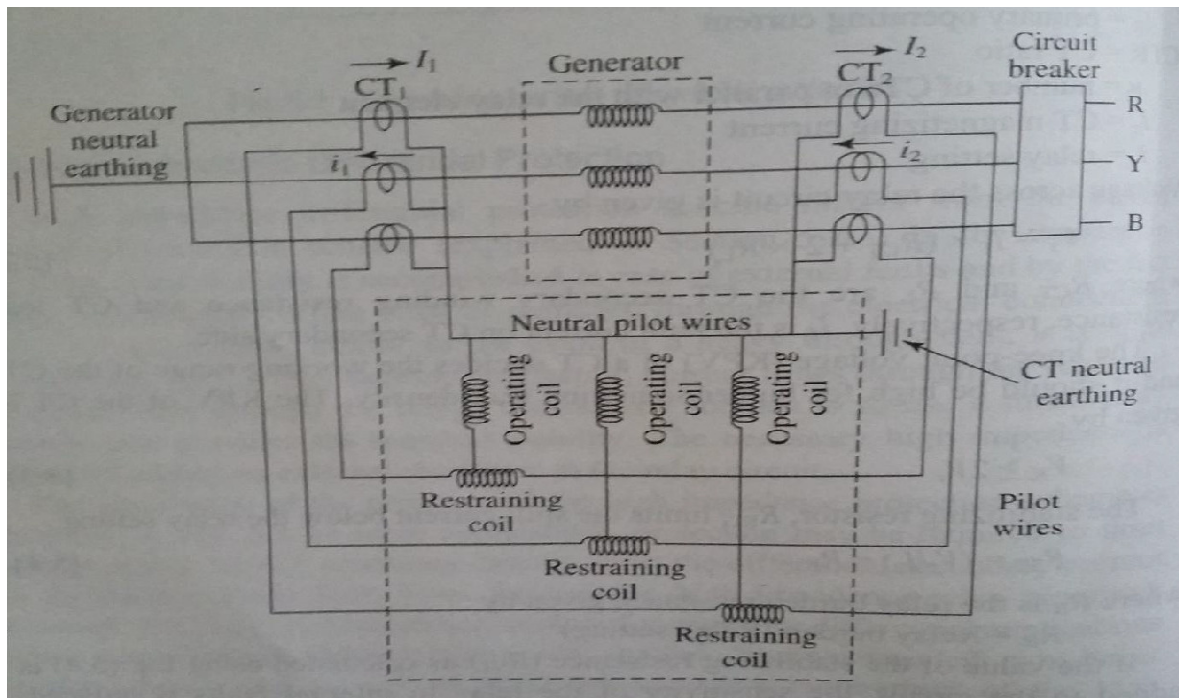

The biased percentage differential relay has 2 settings namely basic setting and bias setting. Basic setting is the difference between two CT secondary currents ($i_1 - i_2$). Bias setting is the ratio of the difference between two CT secondary currents to the average values of two currents ($\frac{i_1 - i_2}{\frac{i_1 + i_2}{2}}$). In the case of a normal condition or external fault condition some amount of spill current ($i_1 - i_2$) is already available because of the non-identical CTs and an equal lead length. However at the same time average value also increases hence fault current will not cross the bias setting of the relay even though the basic setting is exceeded therefore mal-operation of the relay can be avoided.

On the other hand during an internal fault two currents on the primary sides of the CTs become unequal a spill current ($i_1 - i_2$) is produced on the secondary side of the 2 CTs this crosses not only the basic setting limit of the relay but also the bias setting limit because of the increase in spill current and decrease in the average of the two currents. Finally the relay operates and trips the generator as per the requirement. The fundamental advantage of this scheme is that it makes the scheme more permissive towards CT mis-match, thus reducing the relays sensitivity to external faults. More over it provides more sensitivity in case of internal faults.

Rotor Earth Fault Protection:

The rotor circuit of the alternator is not earthed and d.c. voltage is imposed on it. And hence single ground fault in rotor does not cause circulating current to flow through the rotor

circuit. Hence single ground fault in rotor does not cause any damage to it. But single ground fault causes an increase in the stress to ground at other points in the field winding when voltages are induced in the rotor due to transients. Thus the probability of second ground fault increases.

If the second ground fault occurs then part of the rotor winding is bypassed and the currents in the remaining portion increases abruptly. This causes the unbalance of rotor circuit and hence the mechanical and thermal stresses on the rotor. Due to this, rotor may get damaged. Sometimes damage of bearings and bending of rotor shaft take place due to the vibrations. Hence the rotor must be protected against earth fault.

The modern method of providing earth fault protection includes d.c. injection or a.c. injection. The scheme is shown in the Fig.

A small DC power supply is connected to the field circuit. A fault detecting sensitive relay and the resistance are also connected in series with the circuit. This high resistance limits the current through the circuit.

A fault at any point on the field circuit will pass a current of sufficient magnitude through the relay to cause its operation. The d.c. supply is preferred and simple to use and it has no problem of the leakage currents. In case of a.c. injection, the high resistance is replaced by a capacitor.

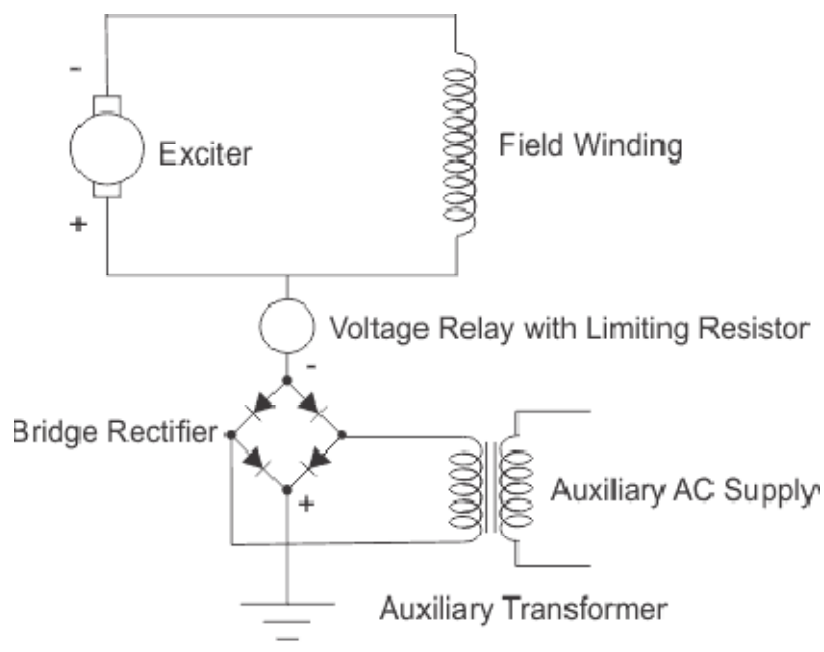

The earth fault relays are instantaneous in operation and are connected to an alarm circuit for indication and to take the proper action. This is because; a single ground fault does not

require an immediate action of isolating the generator.

Restricted Earth Fault Protection:

When the neutral is solidly grounded, it is possible to provide protection to complete winding of the generator against ground faults. However, the neutral is grounded through resistance to limit ground fault currents. With resistance grounding it is not possible to protect the complete winding against ground faults. The percentage of winding protected depends on the value of the neutral grounding resistor and the relay setting. The usual practice is to protect 80 to 85% of the generator winding against ground fault. The remaining 15-20% from neutral end is left unprotected. The relay setting for the differential protection is determined by the value of the neutral grounding resistor and the percentage of winding to be protected. If the ground fault occurs at the point F of the generator winding, the voltage V_{FN} is available to drive the ground-fault current I_f through the neutral to ground connection. If the fault point F is nearer to the neutral point N, the forcing voltage V_{FN} , will be relatively less. Hence, ground fault current I_f will reduce. It is not practicable to keep the relay setting too sensitive to sense the ground fault currents of small magnitudes. Because, if the relay is made too sensitive, it may respond during through faults. The percentage of winding that is left unprotected;

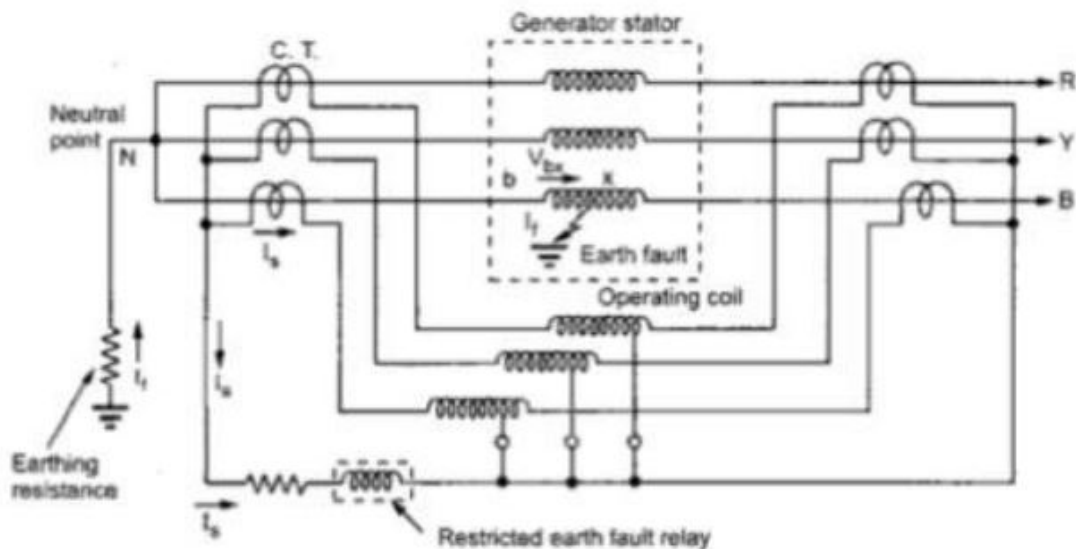

$$\frac{p}{100} = \frac{V_{ph}}{R_n I_f}$$

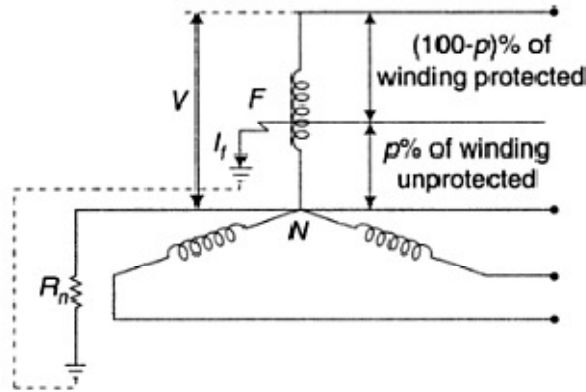

Stator Inter-Turn Protection:

Merz-price circulating-current system protects against phase-to-ground and phase-to-phase faults. It does not protect against turn-to-turn fault on the same phase winding of the stator. It is because the current that this type of fault produces flows in a local circuit between the turns involved and does not create a difference between the currents entering and leaving the winding at its two ends where current transformers are applied. However, it is usually considered unnecessary to provide protection for inter-turn faults because they invariably develop into earth-faults.

In single turn generator there is no necessity of protection against inter-turn faults. However, inter-turn protection is provided for multi-turn generators such as hydro-electric generators. These generators have double-winding armatures as they carry very heavy currents. The relays R_c provide protection against phase-to-ground and phase-to-phase faults whereas relays R_1 provide protection against inter-turn faults.

Two current transformers are connected on the circulating-current principle. Under normal conditions, the currents in the stator windings S_1 and S_2 are equal and so will be the currents in

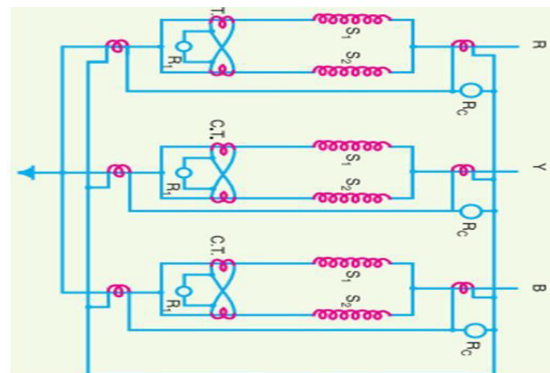

the secondaries of the two CTs. The secondary current round the loop then is the same at all points and no current flows through the relay R_1 . If a short-circuit develops between adjacent turns, say on S_1 , the currents in the stator windings S_1 and S_2 will no longer be equal. Therefore, unequal currents will be induced in the secondaries of CTs and the difference of

these two currents flows through the relay R_I . The relay then closes its contacts to clear the generator from the system.

Transformer Protection

5.1 INTRODUCTION

The power transformer in the power system network is subjected to variety of faults. They include earth-faults, phase to phase faults, inter turns faults, over loading etc. So the transformer should be protected from these faults.

The choice of protection of a particular transformer depends upon its rating, size and whether it has no-load or off-load tap changer for the transformer of small rating, fuses or relays may be used but for large rating transformers are protected using percentage differential protection.

5.2 PERCENTAGE DIFFERENTIAL PROTECTION

As mentioned the percentage differential protection is employed for transformer of large ratings. The differential protection responds to vector difference between two similar actuating quantities. This protection is explained in the following points

1. Two C.T's (Current Transformers) are connected at each end of the transformers
2. Pilot wires are connected between the CT's
3. The CT's are connected in Star or Delta
4. Biased coils are provided in series with pilot wires to avoid unwanted operation
5. The ratio of CT's and its connections should be set, such that the current fed into the pilot wires are equal at normal conditions
6. When there is an internal fault in the transformer such as phase –ground or phase to phase fault, the current are not equal and the difference currents (I_1-I_2) flows through the operating coil of relay.
7. The current flowing through the bias coil is given by $\frac{I_1+I_2}{2}$. This current provides the restraining torque.
8. When operating torque > restraining torque then the relay operates.

Rules for CT Connections :

The CT connection should be such that at normal conditions or external faults, no current should flow through the operating coil of relay.

The Connection of CT Secondary on Star side and Delta-side are shown in Figures drawn

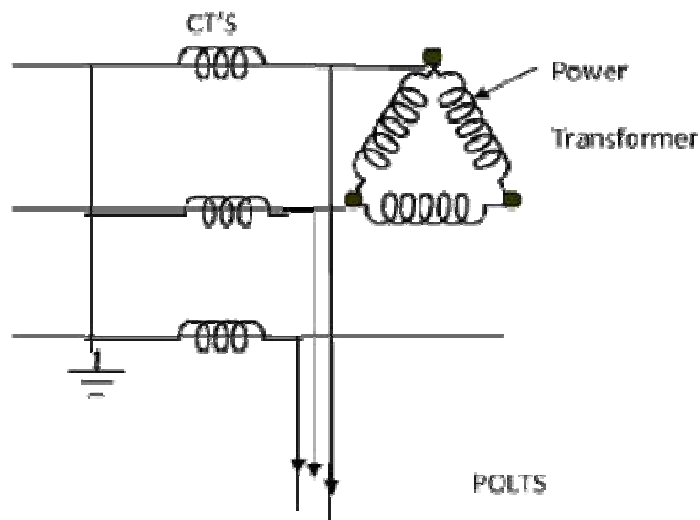
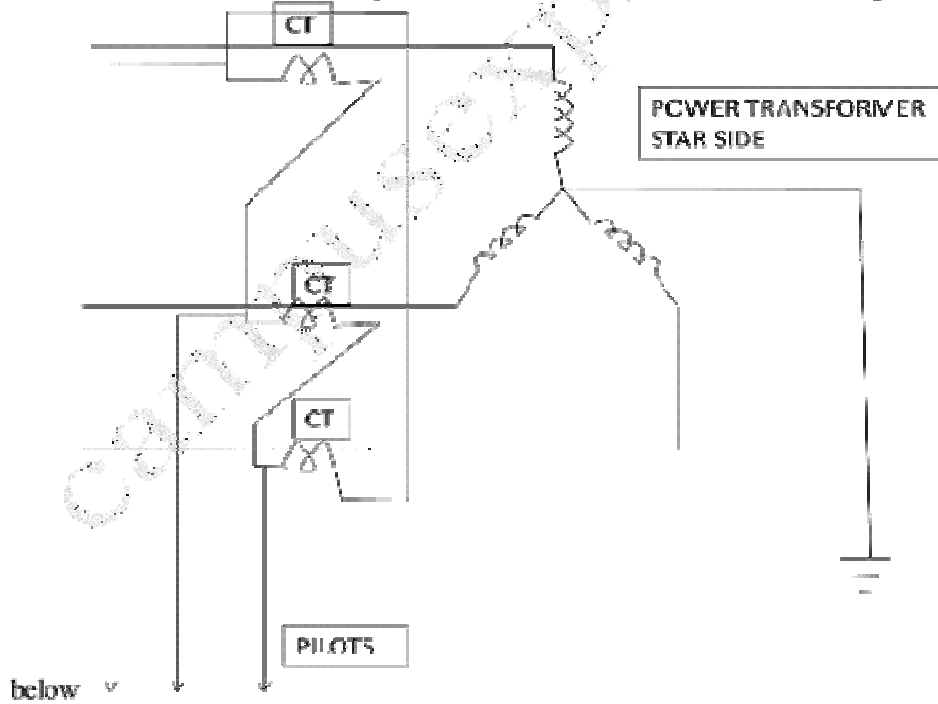

Fig 5.1(b) connection of CT secondary on delta side.

- * In a transformer, the load currents on H.V. side are displaced in phase with respect to the load currents on L.V side. This phase displacement induces phase displacement in CT Secondaries. So this phase displacement provided by Star/Delta connections of CT Secondaries, so that during normal operation the current fed to pilot wires from both sides are in phase with each other.

- * There are four different types of groups based on phase displacement.

	<u>Phase Displacement</u>
Group 1 : Star - Star	0°
Group 2 : Star - Star	180°
Group 3 : Delta - Star	-30°
Group 4 : Delta - Star	30°

The rules to be followed meet the above requirements is

- i) Secondaries of CT's on Star connected side are connected in Delta.
- ii) Secondaries of CT's on delta connected side are connected in Star
- iii) The neutral point of power transformer and CT Star are connected to ground
- iv) Current transformer ratios should be such that the current fed into pilot wires from both ends should be same under normal conditions or external faults. CT's on both sides may have different ratings based on above condition.

For example , current fed into pilot wires is 10Amp, the secondary current of Star connected CT should be 10 Amp and that of delta connected CT should be $10/\sqrt{3}$ Amp.

The relevant diagrams for percentage differential protection of delta-star and star-star connected transformer is shown in figures drawn below.

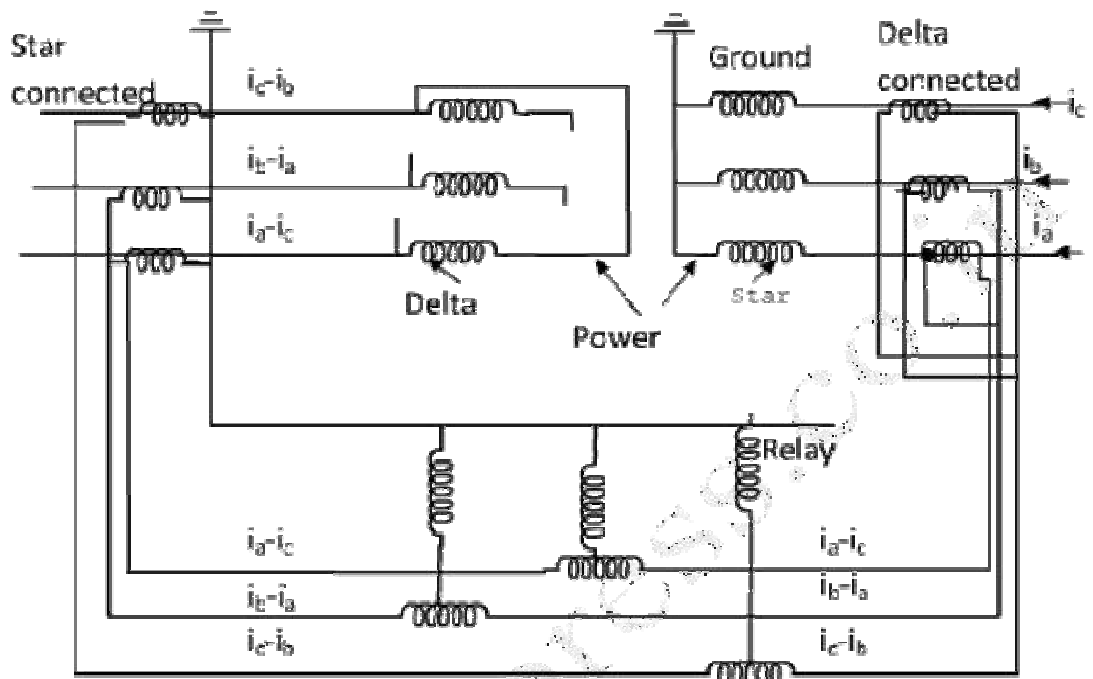

Fig: Differential protection of delta star

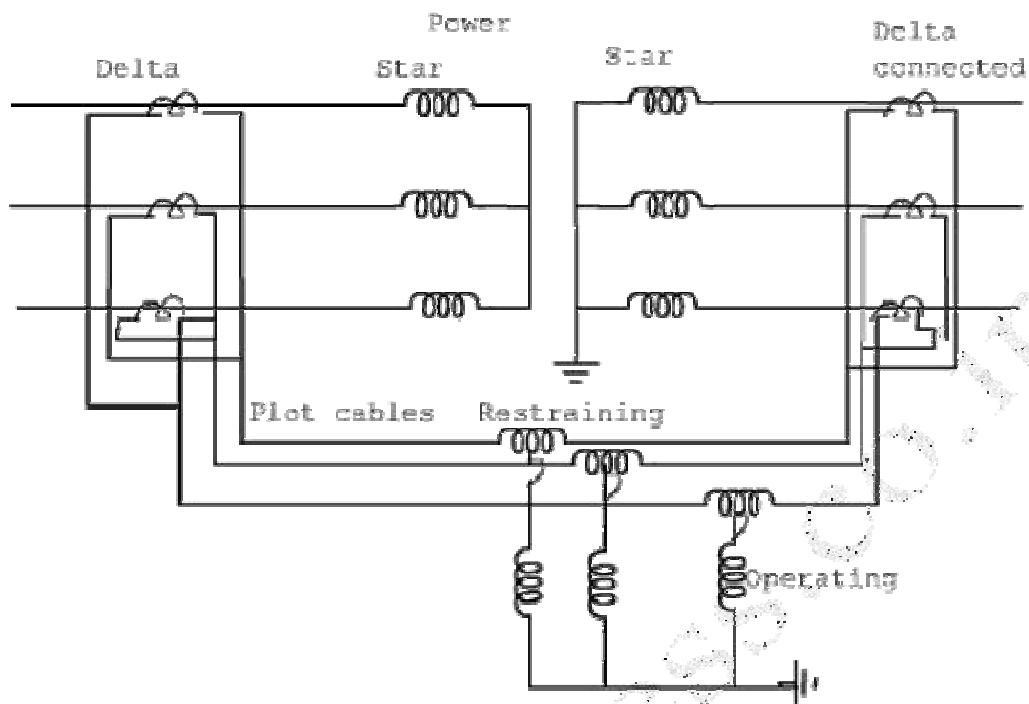

Fig: Differential protection of star-star

5.3 BUCHHÖLZ RELAY PROTECTION

During internal faults in the transformer below oil level, an arc is formed. The heat of arc decomposes the transformer oil to form gases. The rate of formation of these gases depends on arc voltage and fault current. The gases formed can be used to detect those faults. One of the device is Buchholz relay. Buchholz relay is a gas actuated relay specifically gas accumulator relay. Buchholz relay mainly protects against incipient faults.

Principle of operation:-

Principle of operation of Buchholz relay can be explained in the following points with a figure drawn below.

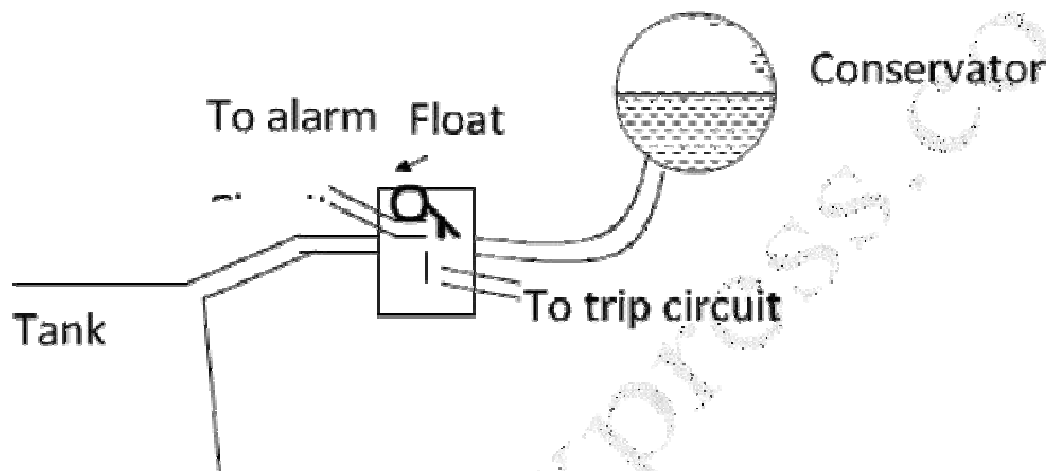

Fig Arrangement of Buchholz relay

1. The gases formed in decomposition of oil contains 70% of hydrogen gas.
2. Since hydrogen gas is light it raise up and tends to go in t conservator.
3. Buchholz relay is fitted in the pipe leading to the conservator as shown in fig 5.3(b).
4. The gases thus gets accumulated in the upper portion of buchholz relay above oil level so that the level of oil drops down.
5. Due to this the float which is floating in the oil tilts down.
6. Due to this tilting the mercury switch connected to the float closes the contacts and gives an alarm.
7. The alarm indicates there is some internal fault in the transformer and the fault should be immediately disconnected.
8. The internal faults may be phase, phase fault, phase ground fault or internal fault.
9. During severe faults the pressure in the tank increases very much.
10. Due o this the oil pushes into the conservator.
11. When the occurs the battle in the Buchholz relay gets pressed due to pressure of oil.
12. Then the mercury switch attached to battle closes its contacts and gives trip signal to stop the operation of transformer.
13. The kind of fault can be known by testing the gas for its color combustibility etc.

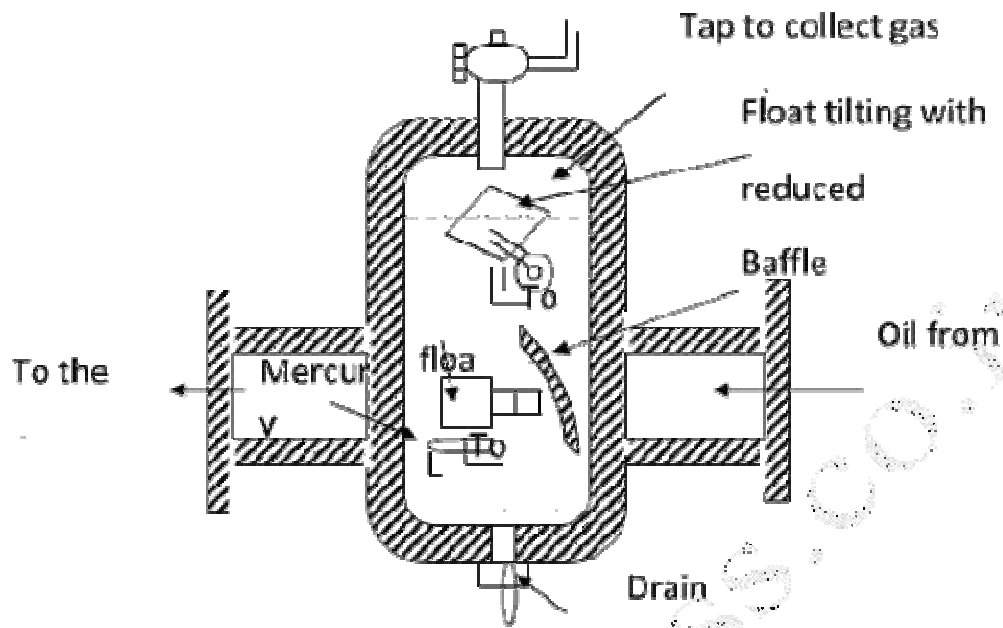

Fig: Buchholz relay principle. (Gas operated Relay)

But there are some limitations to the buchholz relay. They are

1. It cannot detect the faults above oil level.
2. It is employed only for the transformer with conservators.
3. The operating time of the relay is high. So the is very slow.
4. The setting of mercury switch should not be too sensitive otherwise it is effected by shocks, vibrations quakes etc.
5. It is not used for transformers of rating below 500 KV for economical considerations.

Protection of Busbars and Lines

protection is provided to isolate the faulty busbar. The busbar zone, for the purpose of protection, includes not only the busbars themselves but also the isolating switches, circuit breakers and the associated connections. In the event of fault on any section of the busbar, all the circuit equipments connected to that section must be tripped out to give complete isolation.

The standard of construction for busbars has been very high, with the result that bus faults are extremely rare. However, the possibility of damage and service interruption from even a rare bus fault is so great that more attention is now given to this form of protection. Improved relaying methods have been developed, reducing the possibility of incorrect operation. The two most commonly used schemes for busbar protection are :

(i) Differential protection (ii) Fault bus protection

(i) **Differential protection.** The basic method for busbar protection is the differential scheme

in which currents entering and leaving the bus are totalised. During normal load condition, the sum of these currents is equal to zero. When a fault occurs, the fault current upsets the balance and produces a differential current to operate a relay.

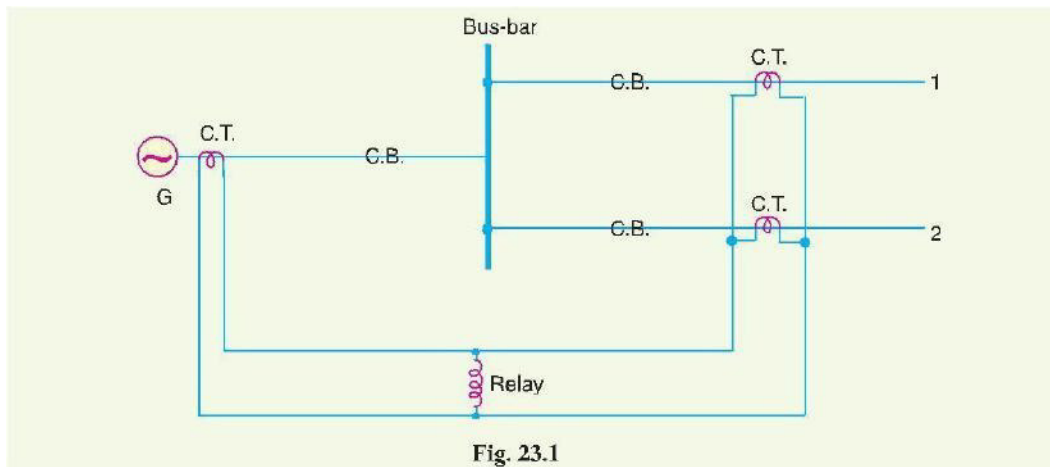

Fig. 23.1 shows the single line diagram of current differential scheme for a station busbar. The busbar is fed by a generator and supplies load to two lines. The secondaries of current transformers in the generator lead, in line 1 and in line 2 are all connected in parallel. The protective relay is connected across this parallel connection. All CTs must be of the same ratio in the scheme regardless of the capacities of the various circuits. Under normal load conditions or external fault conditions, the sum of the currents entering the bus is equal to those leaving it and no current flows through the relay. If a fault occurs within the protected zone, the currents entering the bus will no longer be equal to those leaving it. The difference of these currents will flow through the relay and cause the opening of the generator, circuit breaker and each of the line circuit breakers.

(ii) Fault Bus protection. It is possible to design a station so that the faults that develop are mostly earth-faults. This can be achieved by providing earthed metal barrier (known as *fault bus*) surrounding each conductor throughout its entire length in the bus structure. With this arrangement, every fault that might occur must involve a connection between a conductor and an earthed metal part. By directing the flow of earth-fault current, it is possible to detect the faults and determine their location. This type of protection is known as fault bus protection.

Fig. 23.2 show the schematic arrangement of fault bus protection. The metal supporting structure or fault bus is earthed through a current transformer. A relay is connected across the secondary of this CT. Under normal operating conditions, there is no current flow from fault bus to ground and the relay remains inoperative. A fault involving a connection between a conductor and earthed sup-

Protection of Busbars and Lines

porting structure will result in current flow to ground through the fault bus, causing the relay to operate. The operation of relay will trip all breakers connecting equipment to the bus.

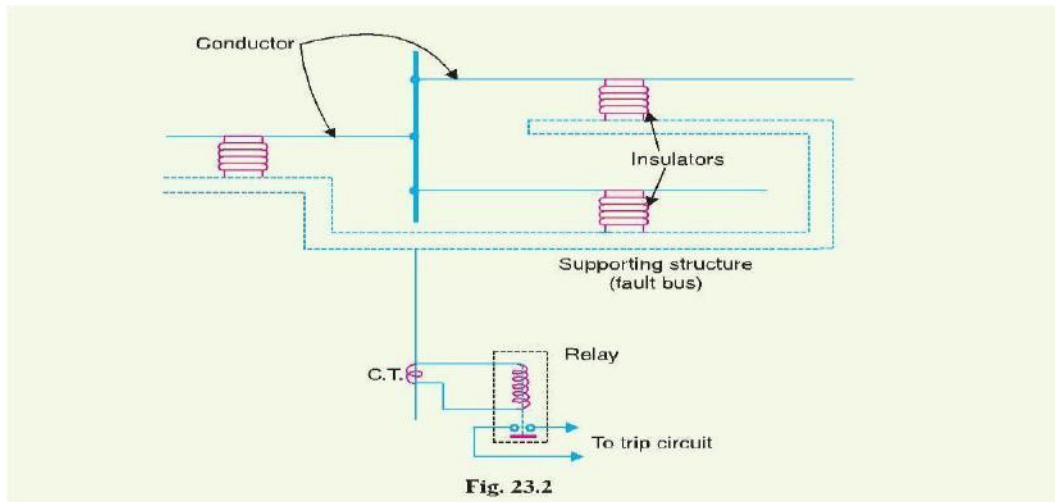

Protection of Lines

The probability of faults occurring on the lines is much more due to their greater length and exposure to atmospheric conditions. This has called for many protective schemes which have no application to the comparatively simple cases of alternators and transformers. The requirements of line protection are :

- (i) In the event of a short-circuit, the circuit breaker closest to the fault should open, all other circuit breakers remaining in a closed position.
- (ii) In case the nearest breaker to the fault fails to open, back-up protection should be provided by the adjacent circuit breakers.
- (iii) The relay operating time should be just as short as possible in order to preserve system stability, without unnecessary tripping of circuits.

The protection of lines presents a problem quite different from the protection of station apparatus such as generators, transformers and busbars. While differential protection is ideal method for lines, it is much more expensive to use. The two ends of a line may be several kilometres apart and to compare the two currents, a costly pilot-wire circuit is required. This expense may be justified but in general less costly methods are used. The common methods of line protection are :

- (i) Time-graded overcurrent protection
- (ii) Differential protection
- (iii) Distance protection

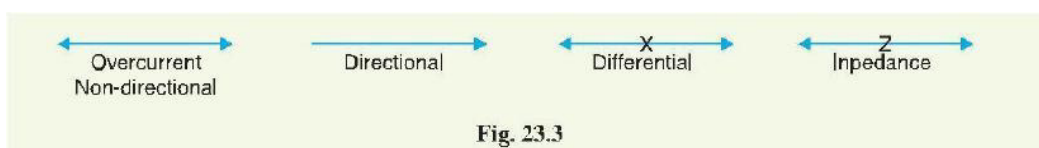
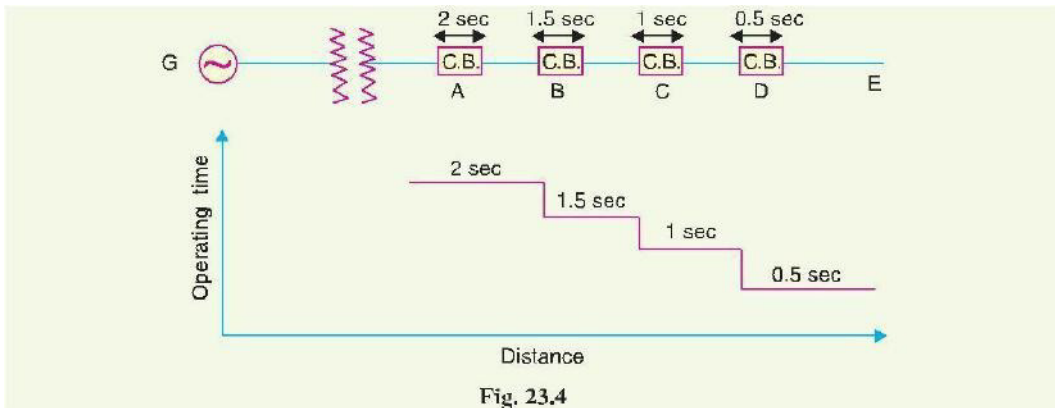

Fig. 23.3 shows the symbols indicating the various types of relay

Time-Graded Overcurrent Protection

In this scheme of overcurrent protection, time discrimination is incorporated. In other words, the time setting of relays is so graded that in the event of fault, the smallest possible part of the system is isolated. We shall discuss a few important cases.

1. Radial feeder. The main characteristic of a radial system is that power can flow only in one direction, from generator or supply end to the load. It has the disadvantage that continuity of supply cannot be maintained at the receiving end in the event of fault. Time-graded protection of a radial feeder can be achieved by using (i) definite time relays and (ii) inverse time relays.



(i) Using definite time relays. Fig. 23.4 shows the overcurrent protection of a radial feeder by definite time relays. The time of operation of each relay is fixed and is independent of the operating current. Thus relay *D* has an operating time of 0.5 second while for other relays, time delay* is successively increased by 0.5 second. If a fault occurs in the section *DE*, it will be cleared in 0.5 second by the relay and circuit breaker at *D* because all other relays have higher operating time. In this way only section *DE* of the system will be isolated. If the relay at *D* fails to trip, the relay at *C* will operate after a time delay of 0.5 second *i.e.* after 1 second from the occurrence of fault.

The disadvantage of this system is that if there are a number of feeders in series, the tripping time for faults near the supply end becomes high (2 seconds in this case). However, in most cases, it is necessary to limit the maximum tripping time to 2 seconds. This disadvantage can be overcome to a reasonable extent by using inverse-time relays.

(ii) Using inverse time relays. Fig. 23.5 shows overcurrent protection of a radial feeder using

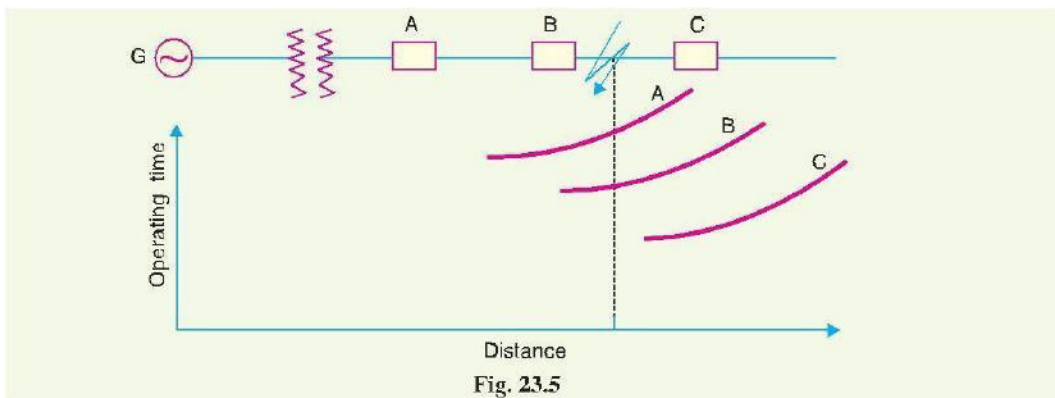

Protection of Busbars and Lines

inverse time relays in which operating time is inversely proportional to the operating current. With this arrangement, the farther the circuit breaker from the generating station, the shorter is its relay operating time.

The three relays at A , B and C are assumed to have inverse-time characteristics. A fault in section BC will give relay times which will allow breaker at B to trip out before the breaker at A .

2. Parallel feeders. Where continuity of supply is particularly necessary, two parallel feeders may be installed. If a fault occurs on one feeder, it can be disconnected from the system and continuity of supply can be maintained from the other feeder. The parallel feeders cannot* be protected by non-directional overcurrent relays only. It is necessary to use directional relays also and to grade the time setting of relays for selective trippings.

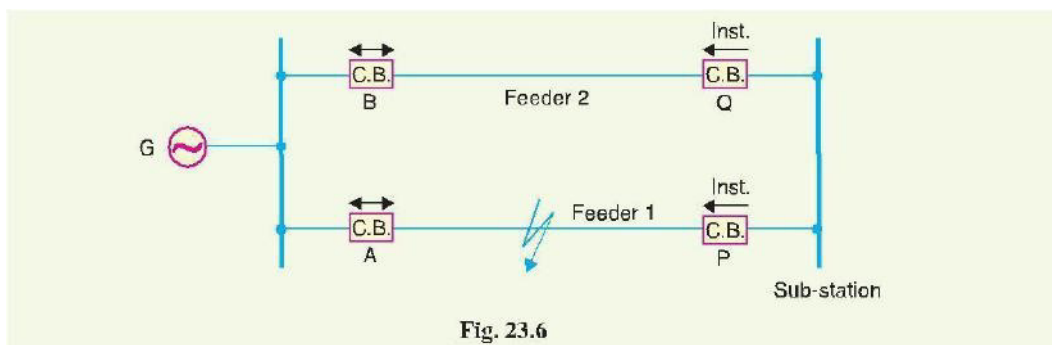
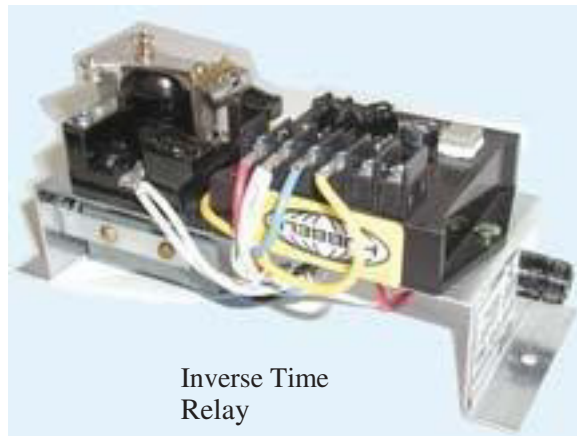

Fig. 23.6 shows the system where two feeders are connected in parallel between the generating station and the sub-station. The protection of this system requires that

- (i) each feeder has a non-directional overcurrent relay at the generator end. These relays should have inverse-time characteristic.
- (ii) each feeder has a reverse power or directional relay at the sub-station end. These relays should be instantaneous type and operate only when power flows in the reverse direction *i.e.* in the direction of arrow at P and Q .

Suppose an earth fault occurs on feeder 1 as shown in Fig. 23.6. It is desired that only circuit breakers at A and P should open to clear the fault whereas feeder 2 should remain intact to maintain the continuity of supply. In fact, the above arrangement accomplishes this job. The shown fault is fed *via* two routes, *viz.*

- (a) directly from feeder 1 *via* the relay A
- (b) from feeder 2 *via* B , Q , sub-station and P

Therefore, power flow in relay Q will be in normal direction but is reversed in the relay P . This causes the opening of circuit breaker at P . Also the relay A will operate while relay B remains inop-

erative. It is because these relays have inverse-time characteristics and current flowing in relay A is in excess of that flowing in relay B . In this way only the faulty feeder is isolated.

3. Ring main system. In this system, various power stations or sub-stations are interconnected by alternate routes, thus forming a closed ring. In case of damage to any section of the ring, that section may be disconnected for repairs, and power will be supplied from both ends of the ring, thereby maintaining continuity of supply.

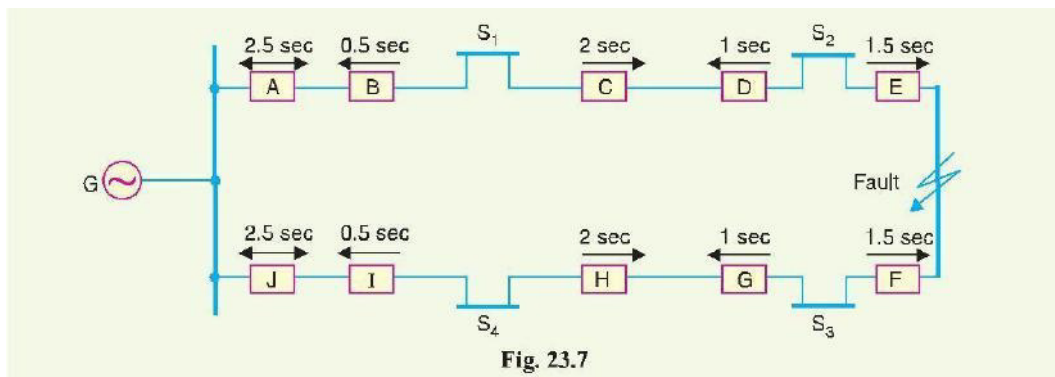

Fig. 23.7 shows the single line diagram of a typical ring main system consisting of one generator G supplying four sub-stations S_1 , S_2 , S_3 and S_4 . In this arrangement, power can flow in both directions under fault conditions. Therefore, it is necessary to grade in both directions round the ring and also to use directional relays. In order that only faulty section of the ring is isolated under fault conditions, the types of relays and their time settings should be as follows :

- (i) The two lines leaving the generating station should be equipped with non-directional overcurrent relays (relays at A and J in this case).
- (ii) At each sub-station, reverse power or directional relays should be placed in both incoming and outgoing lines (relays at B , C , D , E , F , G , H and I in this case).
- (iii) There should be proper relative time-setting of the relays. As an example, going round the loop $G S_1 S_2 S_3 S_4 G$; the outgoing relays (*viz* at A , C , E , G and I) are set with decreasing time limits *e.g.*

$$A = 2.5 \text{ sec}, \quad C = 2 \text{ sec}, \quad E = 1.5 \text{ sec} \quad G = 1 \text{ sec} \text{ and } I = 0.5 \text{ sec}$$

Similarly, going round the loop in the opposite direction (*i.e.* along $G S_4 S_3 S_2 S_1 G$), the *outgoing relays* (J , H , F , D and B) are also set with a decreasing time limit *e.g.*

$$J = 2.5 \text{ sec}, \quad H = 2 \text{ sec}, \quad F = 1.5 \text{ sec}, \quad D = 1 \text{ sec}, \quad B = 0.5 \text{ sec}.$$

Suppose a short circuit occurs at the point as shown in Fig. 23.7. In order to ensure selectivity, it is desired that only circuit breakers at E and F should open to clear the fault whereas other sections of the ring should be intact to maintain continuity of supply. In fact, the above arrangement accomplishes this job. The power will be fed to the fault *via* two routes *viz* (i) from G around S_1 and S_2 and (ii) from G around S_4 and S_3 . It is clear that relays at A , B , C and D as well as J , I , H and G will not trip. Therefore, only relays at E and F will operate before any other relay operates because of their lower time-setting

* **Differential Pilot-Wire Protection**

The differential pilot-wire protection is based on the principle that under normal conditions, the current entering one end of a line is equal to that leaving the other end. As soon as a fault occurs between the two ends, this condition no longer holds and the difference of incoming and outgoing currents is arranged to flow through a relay which operates the circuit breaker to isolate the faulty line. There are several differential protection schemes in use for the lines. However, only the following two schemes will be discussed :

- * Merz-Price voltage balance system
- * Translay scheme

1. Merz-Price voltage balance system. Fig. 23.8 shows the single line diagram of Merz-Price voltage balance system for the protection of a 3-phase line. Identical current transformers are placed in each phase at both ends of the line. The pair of CTs in each line is connected in series with a relay in such a way that under normal conditions, their secondary voltages are equal and in opposition *i.e.* they balance each other.

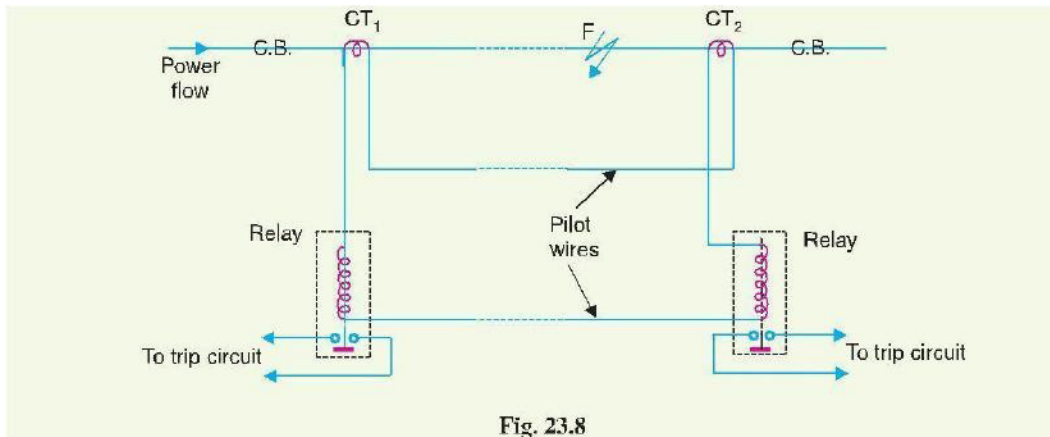
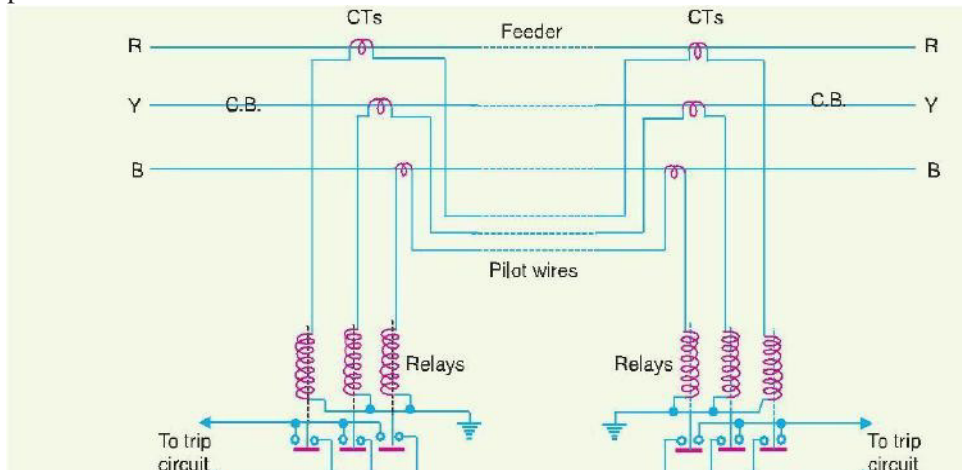

Fig. 23.8

Under healthy conditions, current entering the line at one-end is equal to that leaving it at the other end. Therefore, equal and opposite voltages are induced in the secondaries of the CTs at the two ends of the line. The result is that no current flows through the relays. Suppose a fault occurs at point *F* on the line as shown in Fig. 23.8. This will cause a greater current to flow through CT₁ than through CT₂. Consequently, their secondary voltages become unequal and circulating current flows through the pilot wires and relays. The circuit breakers at both ends of the line will trip out and the faulty line will be isolated

Fig. 23.9 shows the connections of Merz-Price voltage balance scheme for all the three phases of the line.



Advantages

- (i) This system can be used for ring mains as well as parallel feeders.
- (ii) This system provides instantaneous protection for ground faults. This decreases the possibility of these faults involving other phases.
- (iii) This system provides instantaneous relaying which reduces the amount of damage to over-head conductors resulting from arcing faults.

Disadvantages

- (i) Accurate matching of current transformers is very essential.
- (ii) If there is a break in the pilot-wire circuit, the system will not operate.
- (iii) This system is very expensive owing to the greater length of pilot wires required.
- (iv) In case of long lines, charging current due to pilot-wire capacitance* effects may be sufficient to cause relay operation even under normal conditions.
- (v) This system cannot be used for line voltages beyond 33 kV because of constructional difficulties in matching the current transformers.

2. Translay scheme. This system is similar to voltage balance system except that here balance or opposition is between the voltages induced in the secondary windings wound on the relay magnets and

not between the secondary voltages of the line current transformers. This permits to use current transformers of normal design and eliminates one of the most serious

limitations of original voltage balance system, namely ; its limitation to the system operating at voltages not exceeding 33 kV.

The application of Translay scheme for a single phase line has already been discussed in Art. 21.20. This can be extended to 3-phase system by applying one re-

lay at each end of each phase of the 3-phase line. However, it is possible to make further simplification by combining currents derived from all phases in a single relay at each end, using the principle of *summation transformer* (See Fig. 23.10). A summation transformer is a device that reproduces the polyphase line currents as a single-phase quantity. The three lines CTs are connected to the tapped primary of summation transformer. Each line CT energises a different number of turns (from line to neutral) with a resulting single phase output. The use of summation transformer permits two advantages viz (i) primary windings 1 and 2 can be used for phase faults whereas winding 3 can be used for earth fault (ii) the number of pilot wires required is only two.

Schematic arrangement. The Translay scheme for the protection of a 3-phase line is shown in Fig. 23.11. The relays used in the scheme are essentially overcurrent induction type relays. Each relay has two electromagnetic elements. The upper element carries a winding (11 or 11 a) which is energised as a summation transformer from the secondaries of the line CTs connected in the phases of the line to be protected. The upper element also carries a secondary winding (12 or 12 a) which is connected in series with the operating winding (13 or 13 a) on the lower magnet. The secondary windings 12, 12 a and

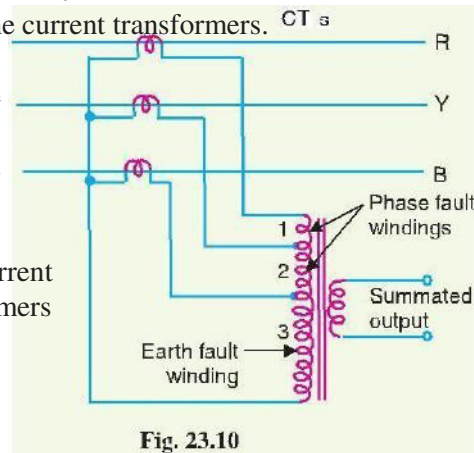

operating windings 13, 13 a are connected in series in such a way that voltages induced in them oppose each other. Note that relay discs and tripping circuits have been omitted in the diagram for clarity

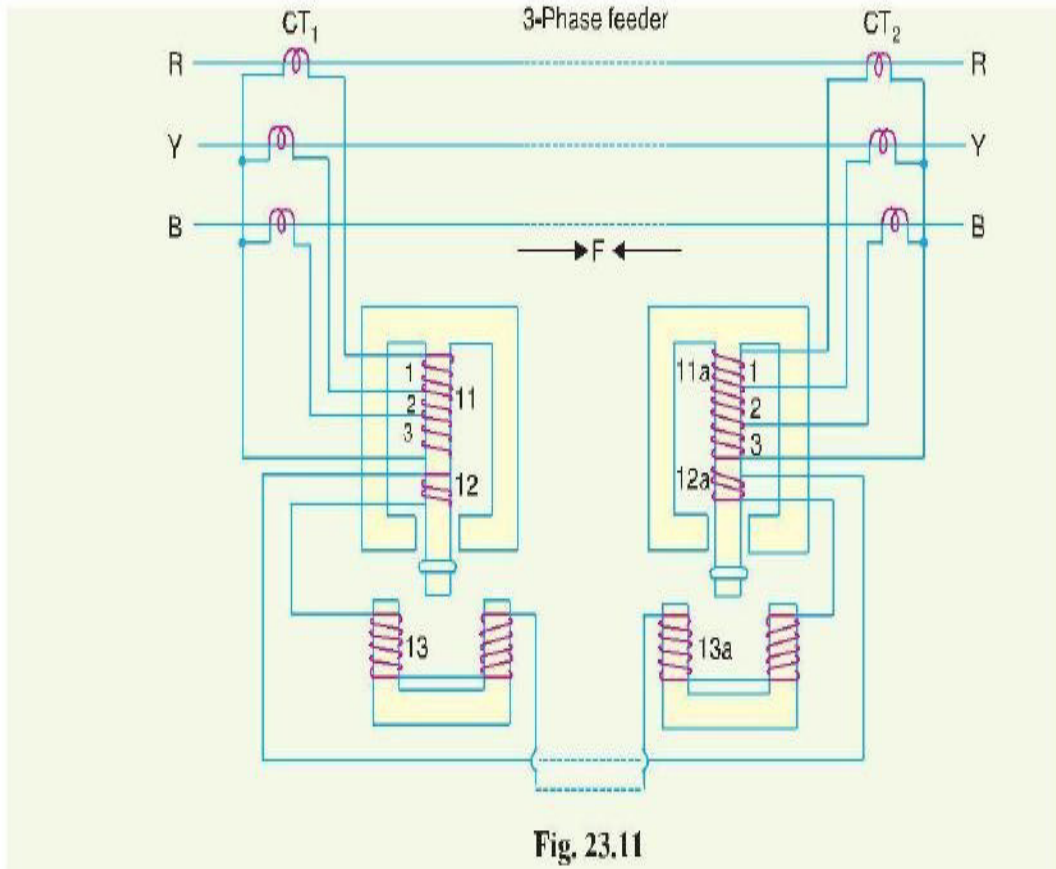

Operation. When the feeder is sound, the currents at its two ends are equal so that the secondary currents in both sets of *CTs* are equal. Consequently, the currents flowing in the relay primary wind-ing 11 and 11 *a* will be equal and they will induce equal voltages in the secondary windings 12 and 12*a*. Since these windings are connected in opposition, no current flows in them or in the operating windings 13 and 13*a*. In the event of a fault on the protected line, the line current at one end must carry a greater current than that at the other end. The result is that voltages induced in the secondary windings 12 and 12 *a* will be different and the current will flow through the operating coils 13, 13*a* and the pilot circuit. Under these conditions, both upper and lower elements of each relay are energised and a forward torque acts on the each relay disc. The operation of the relays will open the circuit breakers at both ends of the line.

- (i) Suppose a fault *F* occurs between phases *R* and *Y* and is fed from both sides as shown in Fig. 23.11. This will energise only section 1 of primary windings 11 and 11*a* and induce voltages in the secondary windings 12 and 12*a*. As these voltages are now additive*, therefore, current will circulate through operating coils 13, 13*a* and the pilot circuit. This will cause the relay contacts to close and open the circuit breakers at both ends. A fault between phases *Y* and *B* energises section 2 of primary windings 11 and 11*a* whereas that between *R* and *B* will energise the sections 1 and 2.
- (ii) Now imagine that an earth fault occurs on phase *R*. This will energise sections 1, 2 and 3 of the primary windings 11 and 11*a*. Again if fault is fed from both ends, the voltages induced in the secondary windings 12 and 12*a* are additive and cause a current to flow through the operating coils 13, 13*a*. The relays, therefore, operate to open the circuit breakers at both ends of the line. In the event of earth fault on phase *Y*, sections 2 and 3 of primary winding 11 and 11*a* will be energised and cause the relays to operate. An earth fault on phase *B* will energise only section 3 of relay primary windings 11 and 11*a*.

Advantages

- (i) The system is economical as only two pilot wires are required for the protection of a 3-phase line.
- (ii) Current transformers of normal design can be used.
- (iii) The pilot wire capacitance currents do not affect the operation of relays.

23.5 Distance Protection

Both time-graded and pilot-wire system are not suitable for the protection of very long high voltage transmission lines. The former gives an unduly long time delay in fault clearance at the generating station end when there are more than four or five sections and the pilot-wire



system becomes too expensive owing to the greater length of pilot wires required. This has led to the development of distance protection in which the action of relay depends upon the distance (or impedance) between the point where the relay is installed and the point of fault. This system provides discrimination protection without employing pilot wires.

The principle and operation of distance relays have already been discussed in chapter 21. We shall now consider its application for the protection of transmission lines. Fig.

23.12 (i) shows a simple system consisting of lines in series such that power can flow only from left to right. The relays at A, B and C are set

to operate

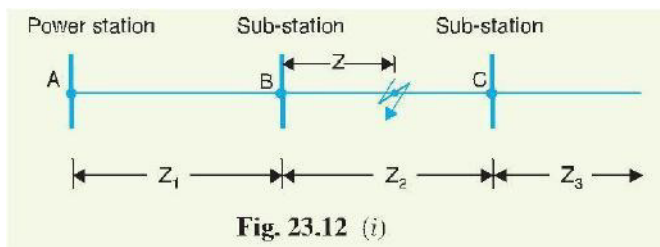

Fig. 23.12 (i)

for impedance less than Z_1 , Z_2 and Z_3 respectively.

Suppose a fault occurs between sub-stations B and C, the fault impedance at power station and sub-station A and B will be $Z_1 + Z$ and Z respectively. It is clear that for the

portion shown, only relay at B will operate. Similarly, if a fault occurs within section A B, then only relay at A will operate. In this manner, instantaneous protection can be obtained for all conditions of operation.

In actual practice, it is not possible to obtain instantaneous protection for complete length of the line due to inaccuracies in the relay elements and instrument transformers. Thus the relay at A [See Fig. 23.12 (i)] would not be very reliable in distinguishing between a fault at 99% of the distance $A B$ and the one at 101% of

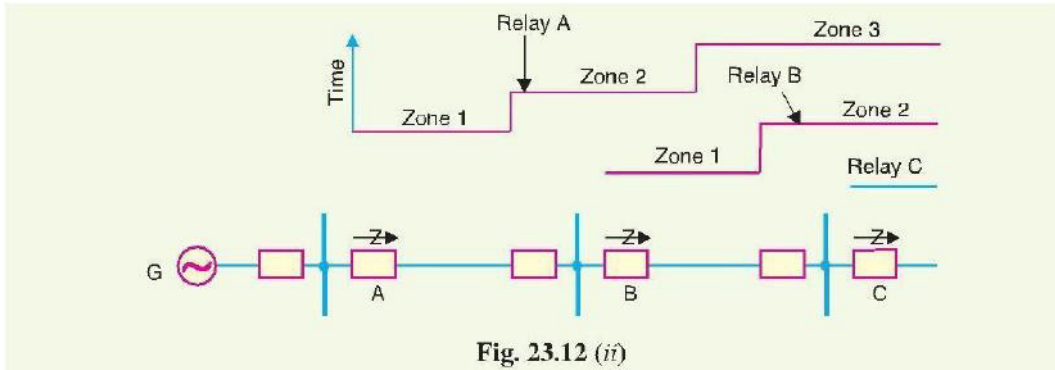

Fig. 23.12 (ii)

distance $A B$. This difficulty is overcome by using 'three-zone' distance protection shown in Fig. 23.12 (ii).

In this scheme of protection, three distance elements are used at each terminal. The zone 1 element covers first 90% of the line and is arranged to trip instantaneously for faults in this portion. The zone 2 element trips for faults in the remaining 10% of the line and for faults in the next line section, but a time delay is introduced to prevent the line from being tripped if the fault is in the next section. The zone 3 element provides back-up protection in the event a fault in the next section is not cleared by its breaker.

Neutral Grounding

Module – IV

In power system, *grounding or earthing means connecting frame of electrical equipment (non-current carrying part) or some electrical part of the system (e.g. neutral point in a star- connected system, one conductor of the secondary of a transformer etc.) to earth i.e. soil. This connection to earth may be through a conductor or some other circuit element (e.g. a resistor, a circuit breaker etc.) depending up on the situation. Regardless of the method of connection to earth, grounding or earthing offers two principal advantages. First, it provides protection to the power system. For example, if the neutral point of a star-connected system is grounded through a circuit breaker and phase to earth fault occurs on any one line, a large fault current will flow through the circuit breaker. The circuit breaker will open to isolate the faulty line. This protects the power system from the harmful effects of the fault. Secondly, earthing of electrical equipment (e.g. domestic appliances, hand-held tools, industrial motors etc.) ensures the safety of the persons handling the equipment. For example, if insulation fails, there will be a direct contact of the live conductor with the metallic part (i.e.frame) of the equipment. Any person in contact with the metallic part of this equipment will be subjected to a dangerous electrical shock which can be fatal. In this chapter, we shall discuss the importance of grounding or earthing in the line of power system with special emphasis on neutral grounding.

Grounding or Earthing:

The process of connecting the metallic frame (i.e. non-current carrying part) of electrical equipment or some electrical part of the system (e.g. neutral point in a star-connected system, one conductor of the secondary of a transformer etc.) to earth (i.e. soil) is called grounding or earthing. It is strange but true that grounding of electrical systems is less understood aspect of power system. Nevertheless, it is a very important subject. If grounding is done systematically in the line of the power system, we can effectively prevent accidents and damage to the equipment of the power system and at the same time continuity of supply can be maintained.

Grounding or earthing may be classified as:

1. Equipment grounding
2. System grounding.

Equipment grounding deals with earthing the non-current-carrying metal parts of the electrical equipment. On the other hand, system grounding means earthing some part of the

electrical system e.g. earthing of neutral point of star-connected system in generating stations and sub-stations. Equipment Grounding the process of connecting non-current-carrying metal parts (i.e. metallic enclosure) of the electrical equipment to earth (i.e. soil) in such a way that in case of insulation failure, the enclosure effectively remains at earth potential is called equipment grounding.

We are frequently in touch with electrical equipment of all kinds, ranging from domestic appliances and hand-held tools to industrial motors. We shall illustrate the need of effective equipment grounding by considering a single-phase circuit composed of a 230 V source connected to a motor M as shown in Fig. 26.1. Note that neutral is solidly grounded at the service entrance. In the interest of easy understanding, we shall divide the discussion into three heads viz.

1. Ungrounded enclosure
2. Enclosure connected to neutral wire
3. Ground wire connected to enclosure.

Ungrounded enclosure:

Fig. 26.1 shows the case of ungrounded metal enclosure. If a person touches the metal enclosure, nothing will happen if the equipment is functioning correctly. But if the winding insulation becomes faulty, the resistance R_e between the motor and enclosure drops to a low value (a few hundred ohms or less). A person having a body resistance R_b would complete the current path as shown in Fig. 26.1.

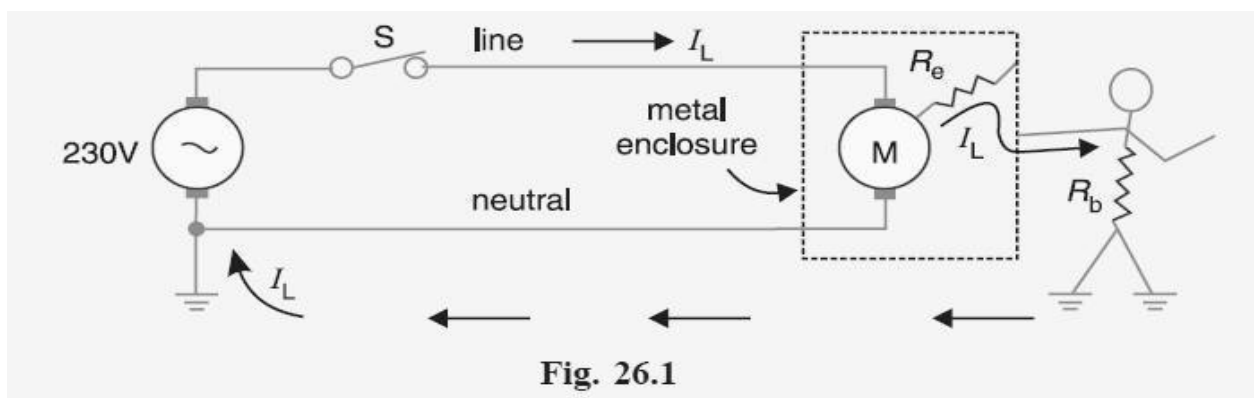

If R_e is small (as is usually the case when insulation failure of winding occurs), the leakage current I_L through the person's body could be dangerously high. As a result, the person

would get severe

*electric shock which may be fatal. Therefore, this system is unsafe.

(ii) Enclosure connected to neutral wire. It may appear that the above problem can be solved by

connecting the enclosure to the grounded neutral wire as shown in Fig. 26.2. Now the leakage current I_L flows from the motor, through the enclosure and straight back to the neutral wire (See Fig. 26.2). Therefore, the enclosure remains at earth potential.

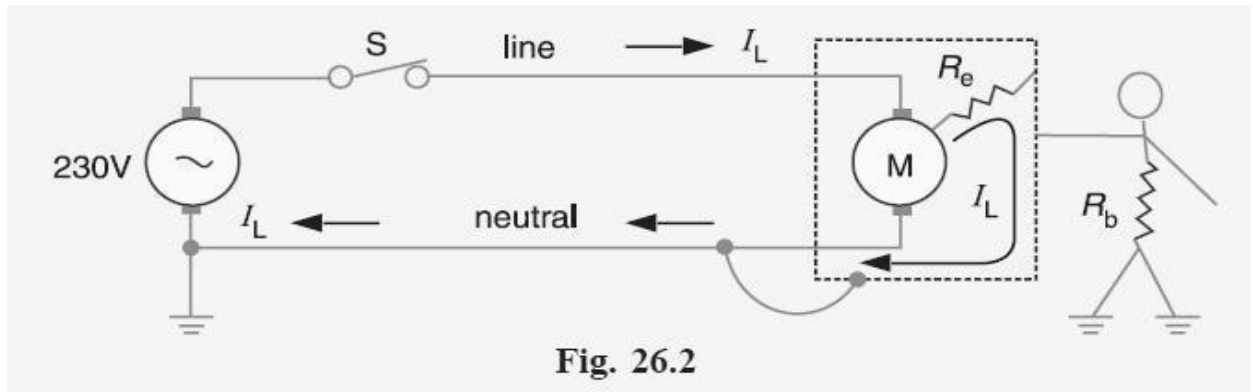

Fig. 26.2

Consequently, the operator would not experience any electric shock.

The trouble with this method is that the neutral wire may become open either accidentally or due to a faulty installation. For example, if the switch is inadvertently in series with the neutral rather than the live wire (See Fig. 26.3), the motor can still be turned on and off. However, if someone touched the enclosure while the motor is off, he would receive a severe electric shock (See Fig. 26.3). It is because when the motor is off, the potential of the enclosure rises to that of the live conductor.

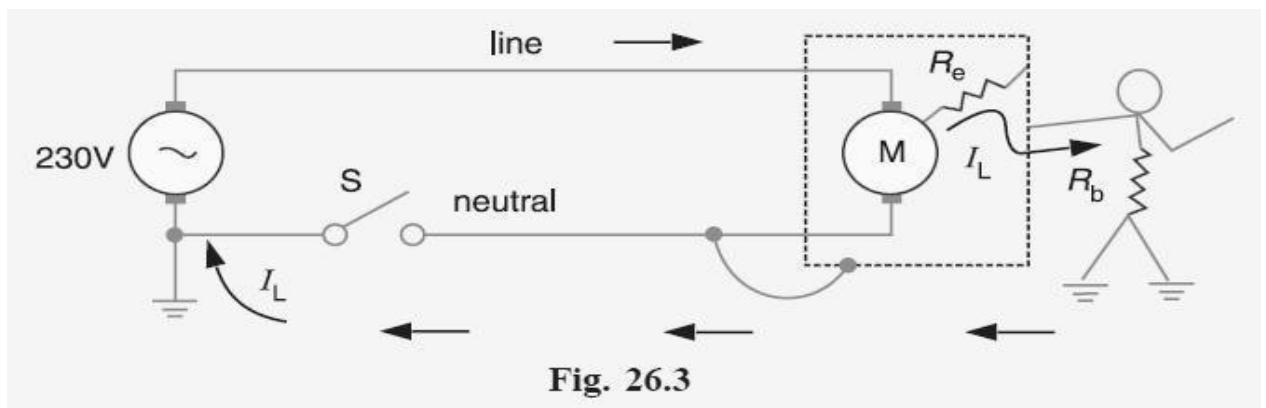

Fig. 26.3

(iii) Ground wire connected to enclosure. To get rid of this problem, we install a third wire, called ground wire, between the enclosure and the system ground as shown in Fig. 26.4. The ground wire may be bare or insulated. If it is insulated, it is coloured green.

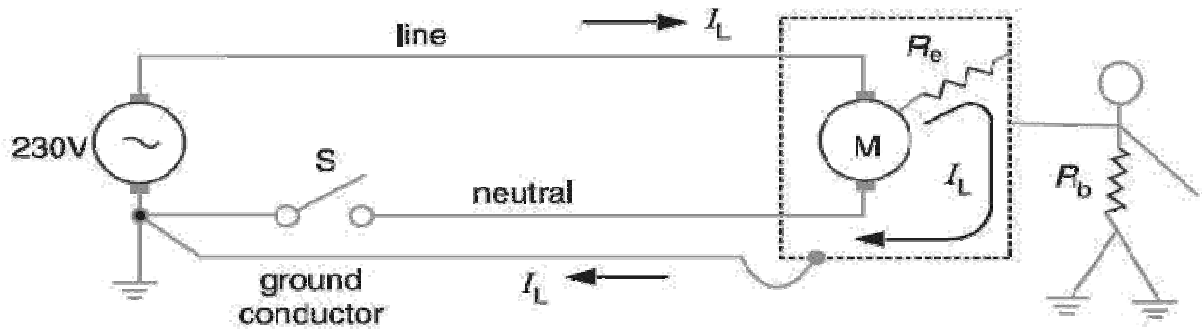

Fig. 26.4

Electrical outlets have three contacts — one for live wire, one for neutral wire and one for ground wire.

System Grounding:

The process of connecting some electrical part of the power system (e.g. neutral point of a star-connected system, one conductor of the secondary of a transformer etc.) to earth (i.e. soil) is called system grounding.

The system grounding has assumed considerable importance in the fast expanding power system. By adopting proper schemes of system grounding, we can achieve many advantages including protection, reliability and safety to the power system network. But before discussing the various aspects of neutral grounding, it is desirable to give two examples to appreciate the need of system grounding.

Fig. 26.5 (i) shows the primary winding of a distribution transformer connected between the line and neutral of a 11 kV line. If the secondary conductors are ungrounded, it would appear that a person could touch either secondary conductor without harm because there is no ground return. However, this is not true. Referring to Fig. 26.5, there is capacitance C_1 between primary and secondary and capacitance C_2 between secondary and ground. This capacitance coupling can produce a high voltage between the secondary lines and the ground. Depending upon the relative magnitudes of C_1 and C_2 , it may be as high as 20% to 40% of the primary voltage. If a person touches either one of the secondary wires, the resulting capacitive current I_C flowing through the body could be dangerous even in case of small transformers [See Fig. 26.5(ii)]. For example, if I_C is only 20 mA, the person may get a fatal electric shock.

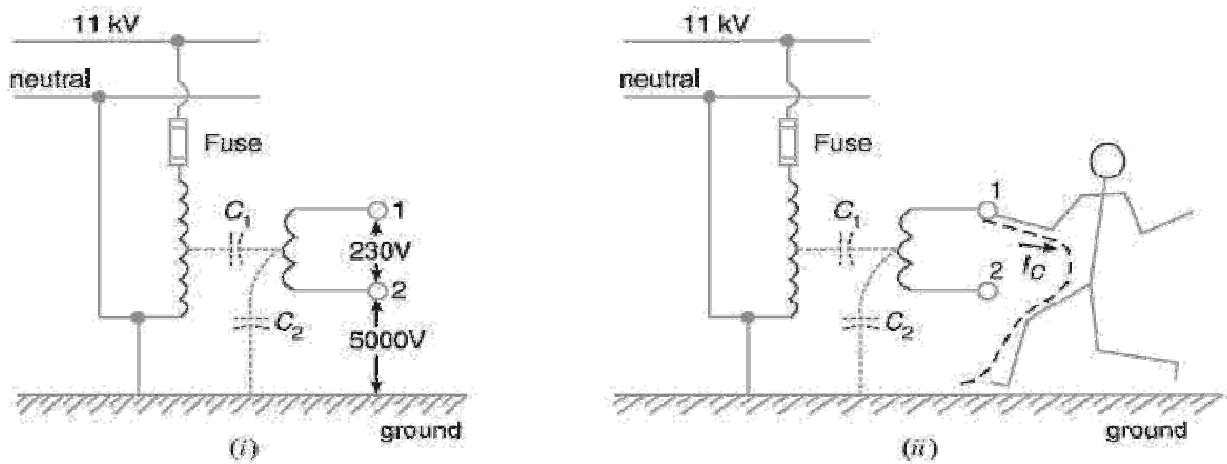

Fig. 26.5

If one of the secondary conductors is grounded, the capacitive coupling almost reduces to zero and so is the capacitive current I_C . As a result, the person will experience no electric shock. This explains the importance of system grounding.

(ii) Let us now turn to a more serious situation. Fig. 26.6 (i) shows the primary winding of a distribution transformer connected between the line and neutral of a 11 kV line. The secondary conductors are ungrounded. Suppose that the high voltage line (11 kV in this case) touches the 230 V conductor as shown in Fig. 26.6 (i). This could be caused by an internal fault in the transformer or by a branch or tree falling across the 11 kV and 230 V lines. Under these circumstances, a very high voltage is imposed between the secondary conductors and ground. This would immediately puncture the 230 V insulation, causing a massive flashover. This flashover could occur anywhere on the secondary network, possibly inside a home or factory. Therefore, ungrounded secondary in this case is a potential fire hazard and may produce grave accidents under abnormal conditions.

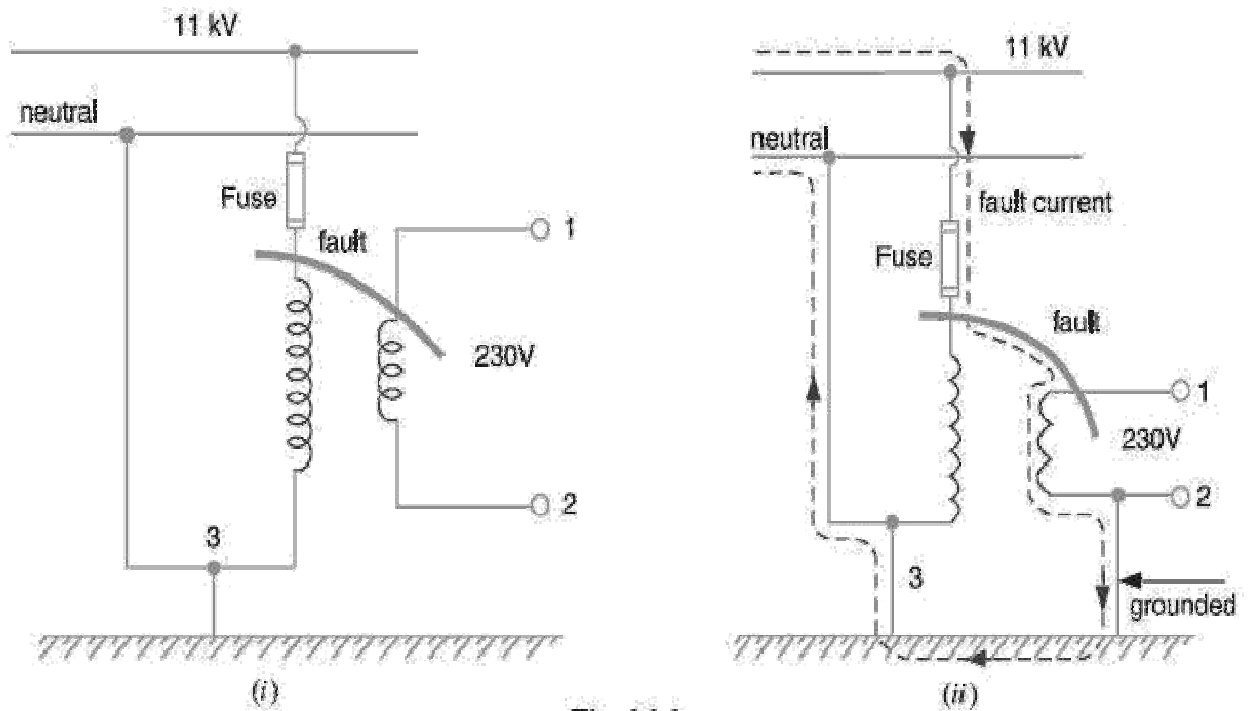

Fig. 26.6

If one of the secondary lines is grounded as shown in Fig. 26.6(ii), the accidental contact between a 11 kV conductor and a 230 V conductor produces a dead short. The short-circuit current (i.e. fault current) follows the dotted path shown in Fig. 26.6 (ii). This large current will blow the fuse on the 11 kV side, thus disconnecting the transformer and secondary distribution system from the 11 kV line. This explains the importance of system grounding in the line of the power system.

Ungrounded Neutral System:

In an ungrounded neutral system, the neutral is not connected to the ground i.e. the neutral is isolated from the ground. Therefore, this system is also called isolated neutral system or free neutral system. Fig. 26.7 shows ungrounded neutral system. The line conductors have capacitances between one another and to ground. The former are delta-connected while the latter are star-connected. The delta-connected capacitances have little effect on the grounding characteristics of the system (i.e. these capacitances do not effect the earth circuit) and, therefore, can be neglected. The circuit then reduces to the one shown in Fig. 26.8(i).

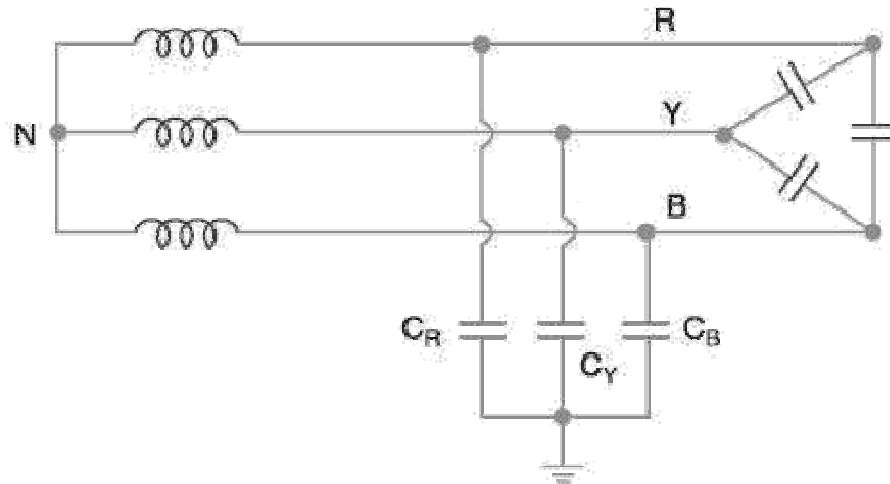

Fig. 26.7

Circuit behaviour under normal conditions. Let us discuss the behavior of ungrounded neutral system under normal conditions (i.e. under steady state and balanced conditions). The line is assumed to be perfectly transposed so that each conductor has the same capacitance to ground.

Therefore, $C_R = C_Y = C_B = C$ (say). Since the phase voltages V_{RN} , V_{YN} and V_{BN} have the same magnitude (of course, displaced 120° from one another), the capacitive currents I_R , I_Y and I_B will have the same value i.e.

$$I_R = I_Y = I_B = V_{ph}/XC \text{ in magnitude}$$

Where V_{ph} = Phase voltage (i.e. line-to-neutral voltage) XC = Capacitive reactance of the line to ground

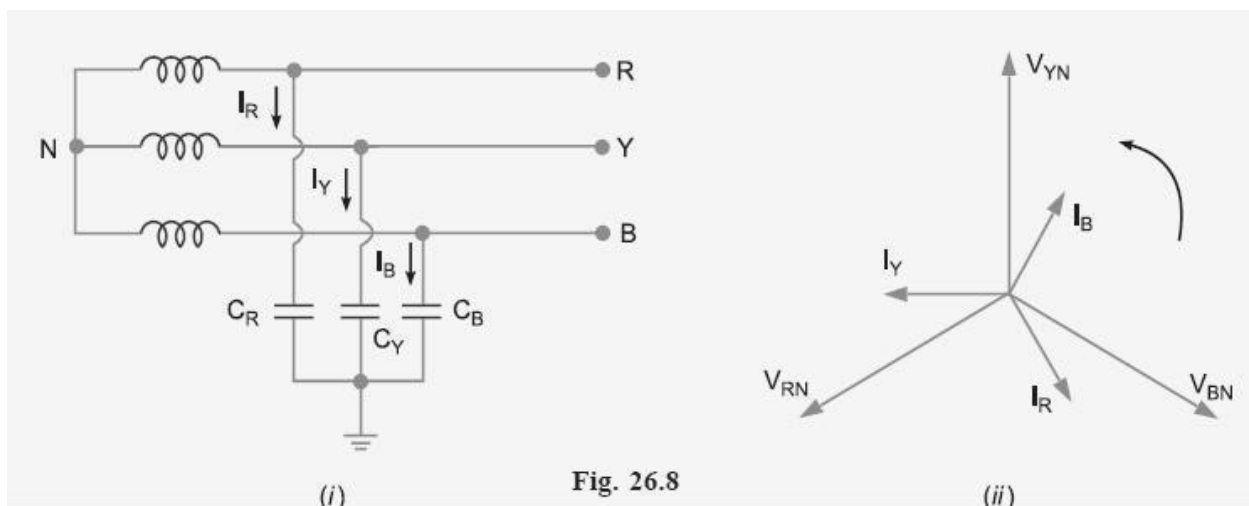

Fig. 26.8

The capacitive currents I_R , I_Y and I_B lead their respective phase voltages V_{RN} , V_{YN} and V_{BN} by 90° as shown in the phasor diagram in Fig. 26.8(ii). The three capacitive currents

are equal in magnitude

and are displaced 120° from each other. Therefore, their phasor sum is zero. As a result, no current flows to ground and the potential of neutral is the same as the ground potential. Therefore, ungrounded neutral system poses no problems under normal conditions. However, as we shall see, currents and voltages are greatly influenced during fault conditions. Circuit behavior under single line to ground-fault. Let us discuss the behavior of ungrounded neutral system when single line to ground fault occurs. Suppose line to ground fault occurs in line B at some point F. The circuit then becomes as shown in Fig. 26.9(i). The capacitive currents I_R and I_Y flow through the lines R and Y respectively. The voltages driving I_R and I_Y are V_{BR} and V_{BY} respectively. Note that V_{BR} and V_{BY} are the line voltages [See Fig. 26.9 (ii)]. The paths of I_R and I_Y are essentially capacitive. Therefore, I_R leads V_{BR} by 90° and I_Y leads V_{BY} by 90° as shown in Fig. 26.9 (ii). The capacitive fault current I_C in line B is the phasor sum of I_R and I_Y .

$$\begin{aligned} \text{Fault current in line B, } & I_C = I_R + I_Y \quad \dots \text{ Phasor sum} \\ \text{Now, } & I_R = \frac{V_{BR}}{X_C} = \frac{\sqrt{3} V_{ph}}{X_C} \\ \text{and } & I_Y = \frac{V_{BY}}{X_C} = \frac{\sqrt{3} V_{ph}}{X_C} \\ \therefore & I_R = I_Y = \frac{\sqrt{3} V_{ph}}{X_C} \end{aligned}$$

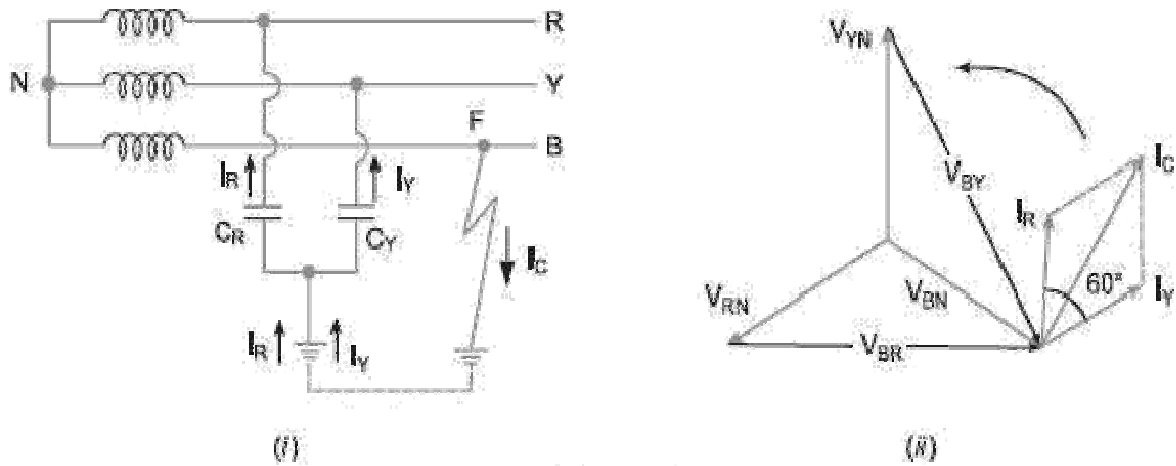

Fig. 26.9

$$= \sqrt{3} \times \text{Per phase capacitive current under normal conditions}$$

Capacitive fault current in line B is

$$\begin{aligned}
 I_C &= \text{Phasor sum of } I_R \text{ and } I_Y \\
 &= \sqrt{3} I_R = \sqrt{3} \times \frac{\sqrt{3} V_{ph}}{X_C} = \frac{3V_{ph}}{X_C}
 \end{aligned}$$

$$\begin{aligned}
 \therefore I_C &= \frac{3V_{ph}}{X_C} = 3 \times \frac{V_{ph}}{X_C} \\
 &= 3 \times \text{Per phase capacitive current under normal conditions}
 \end{aligned}$$

Therefore, when single line to ground fault occurs on an ungrounded neutral system, the following effects are produced in the system:

- The potential of the faulty phase becomes equal to ground potential. However, the voltages of the two remaining healthy phases rise from their normal phase voltages to full line value
this may result in insulation breakdown.
- The capacitive current in the two healthy phases increase to 3 times the normal value.
- The capacitive fault current (I_C) becomes 3 times the normal per phase capacitive current.
- This system cannot provide adequate protection against earth faults. It is because the capacitive fault current is small in magnitude and cannot operate protective devices.

The capacitive fault current I_C flows into earth, experience shows that I_C in excess of 4A is sufficient to maintain an arc in the ionized path of the fault. If this current is once maintained, it may exist even after the earth fault is cleared. This phenomenon of *persistent arc is called arcing ground. Due to arcing ground, the system capacity is charged and discharged in a cyclic order. This set up high frequency oscillations on the whole system and the phase voltage of healthy conductors

may rise to 5 to 6 times its normal value. The over voltages in healthy conductors may damage the insulation in the line. Due to above disadvantages, ungrounded neutral system is not used these days. The modern high voltage 3-phase systems employ grounded neutral owing to a number of advantages.

Neutral Grounding

The process of connecting neutral point of 3-phase system to earth (i.e. soil) either directly or through some circuit element (e.g. resistance, reactance etc.) is called neutral grounding.

Neutral grounding provides protection to personal and equipment. It is because during earth fault, the current path is completed through the earthed neutral and the protective devices (e.g. a fuse etc.) operate to isolate the faulty conductor from the rest of

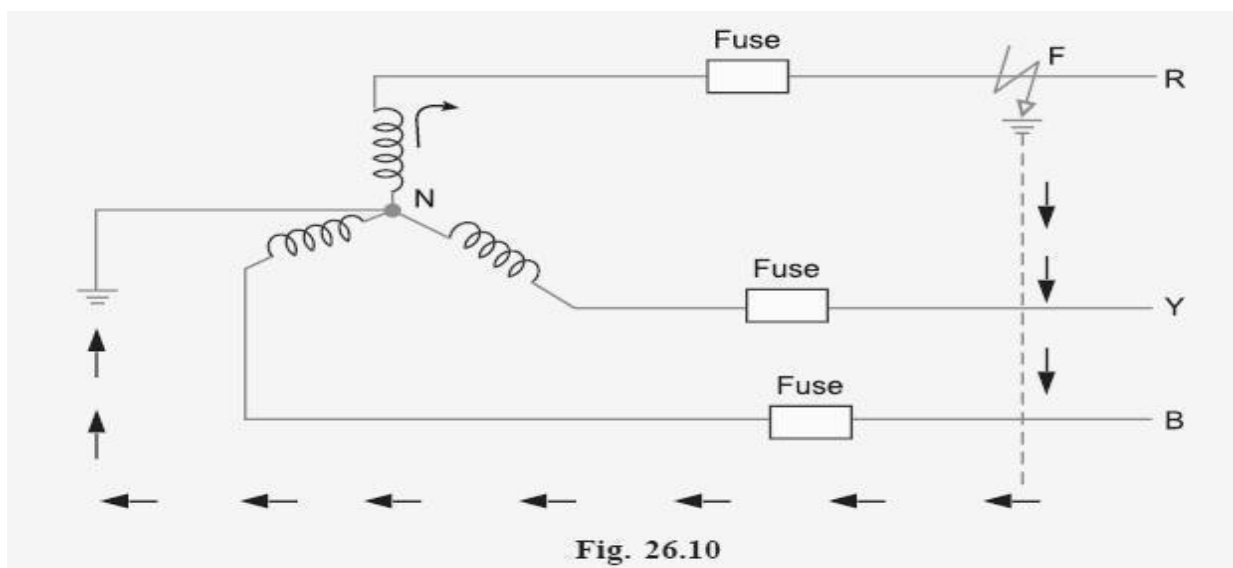

Fig. 26.10

the system. This point is illustrated in Fig. 26.10.

Fig. 26.10 shows a 3-phase, star-connected system with neutral earthed (i.e. neutral point is connected to soil). Suppose a single line to ground fault occurs in line R at point F. This will cause the current to flow through ground path as shown in Fig. 26.10. Note that current flows from R- phase to earth, then to neutral point N and back to R-phase. Since the impedance of the current path is low, a large current flows through this path. This large current will blow the fuse in R-phase and isolate the faulty line R. This will protect the system from the harmful effects (e.g. damage to equipment, electric shock to personnel etc.) of the fault. One important feature of grounded neutral is that the potential difference between the live conductor and ground will not exceed the phase voltage of the system i.e. it will remain nearly constant.

Advantages of Neutral Grounding

The following are the advantages of neutral grounding :

- Voltages of the healthy phases do not exceed line to ground voltages i.e. they remain nearly constant.
- The high voltages due to arcing grounds are eliminated.
- The protective relays can be used to provide protection against earth faults. In case earth fault occurs on any line, the protective relay will operate to isolate the faulty line.
- The over voltages due to lightning are discharged to earth.
- It provides greater safety to personnel and equipment.
- It provides improved service reliability.
- Operating and maintenance expenditures are reduced.

Note: It is interesting to mention here that ungrounded neutral has the following advantages:

- In case of earth fault on one line, the two healthy phases will continue to supply load for a short period.
- Interference with communication lines is reduced because of the absence of zero sequence currents.
- The advantages of ungrounded neutral system are of negligible importance as compared to the advantages of the grounded neutral system. Therefore, modern 3-phase systems operate with grounded neutral points.

Methods of Neutral Grounding:

The methods commonly used for grounding the neutral point of a 3-phase system are :

1. Solid or effective grounding
2. Resistance grounding
3. Reactance grounding
4. Peterson-coil grounding

The choice of the method of grounding depends upon many factors including the size of the system, system voltage and the scheme of protection to be used.

Solid Grounding:

When the neutral point of a 3-phase system (e.g. 3-phase generator, 3-phase transformer etc.) is directly *connected to earth (i.e. soil) through a wire of negligible resistance and reactance, it is called solid grounding or effective grounding. Fig. 26.11 shows the solid grounding of the neutral point. Since the neutral point is directly connected to earth through a wire, the neutral point is held at Fig. 26.11 earth potential under all

conditions. Therefore, under fault conditions, the voltage of any

conductor to earth will not exceed the normal phase voltage of the system.

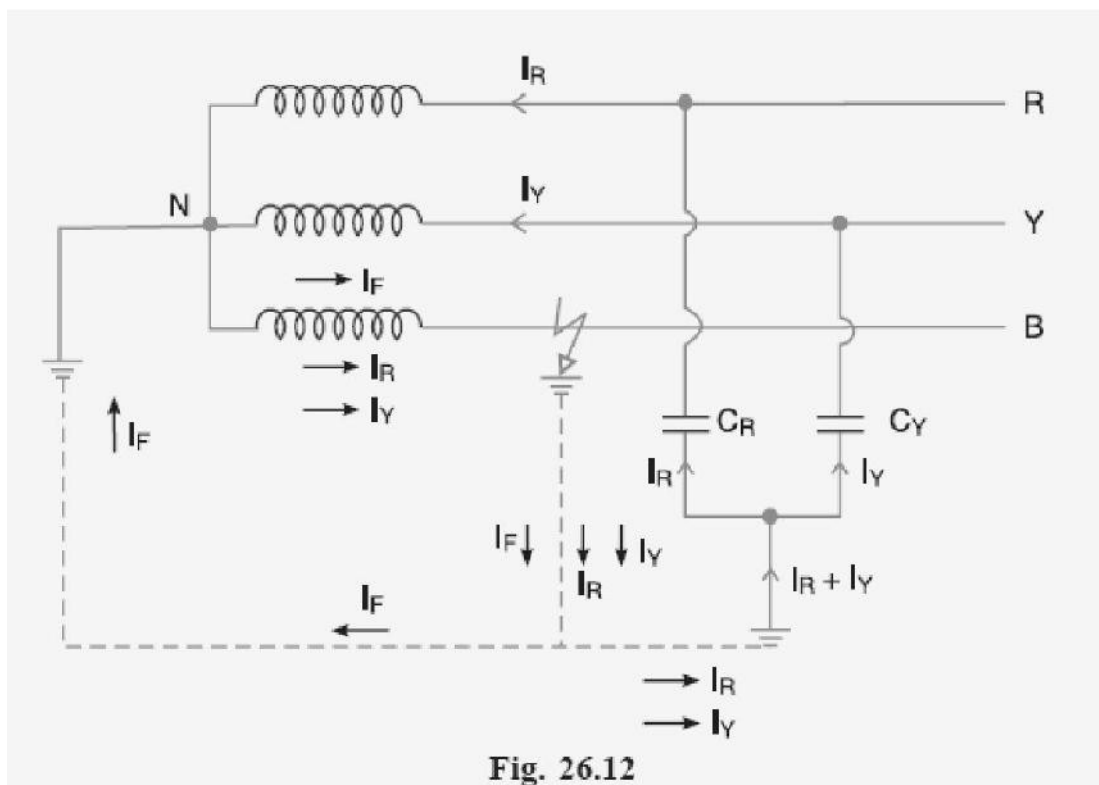
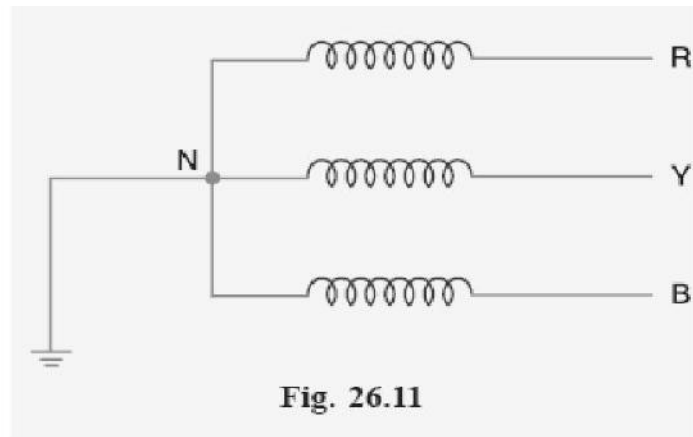

The solid grounding of neutral point has the following advantages :

- The neutral is effectively held at earth potential.
- When earth fault occurs on any phase, the resultant capacitive current I_C is in phase

opposition to the fault current I_F . The two currents completely cancel each other. Therefore, no arcing ground or over voltage conditions can occur. Consider a line to ground fault in line B as shown in Fig. 26.12. The capacitive currents flowing in the healthy phases R and Y are I_R and I_Y respectively. The resultant capacitive current I_C is the phasor sum of I_R and I_Y . In addition to these capacitive currents, the power source also supplies the fault current I_F .

- This fault current will go from fault point to earth, then to neutral point N and back to the fault point through the faulty phase. The path of I_C is capacitive and that of I_F is inductive.

The two currents are in phase opposition and completely cancel each other. Therefore, no arcing ground phenomenon or over-voltage conditions can occur.

- When there is an earth fault on any phase of the system, the phase to earth voltage of the faulty phase becomes zero. However, the phase to earth voltages of the remaining two healthy phases remain at normal phase voltage because the potential of the neutral is fixed at earth potential. This permits to insulate the equipment for phase voltage. Therefore, there is a saving in the cost of equipment.

- It becomes easier to protect the system from earth faults which frequently occur on the system. When there is an earth fault on any phase of the system, a large fault current flows between the fault point and the grounded neutral. This permits the easy operation of earth fault relay.

The following are the disadvantages of solid grounding :

- Since most of the faults on an overhead system are phase to earth faults, the system has to bear a large number of severe shocks. This causes the system to become unstable.
- The solid grounding results in heavy earth fault currents. Since the fault has to be cleared by the circuit breakers, the heavy earth fault currents may cause the burning of circuit breaker contacts.
- The increased earth fault current results in greater interference in the neighbouring communication lines.

Applications:

Solid grounding is usually employed where the circuit impedance is sufficiently high so as to keep the earth fault current within safe limits. This system of grounding is used for voltages upto 33 kV with total power capacity not exceeding 5000 kVA.

Resistance Grounding:

In order to limit the magnitude of earth fault current, it is a common practice to connect the neutral point of a 3-phase system to earth through a resistor. This is called resistance grounding.

When the neutral point of a 3-phase system (e.g. 3-phase generator, 3-phase transformer etc.) is connected to earth (i.e. soil) through a resistor, it is called resistance grounding. Fig. 26.13 shows the grounding of neutral point through a resistor R . The value of R should neither be very low nor very high. If the value of earthing resistance R is very low, the earth fault current will be large and the system becomes similar to the solid grounding system. On the other hand, if the earthing resistance R is very high, the system conditions become similar to ungrounded neutral system. The value of R is so chosen such that the earth fault current is limited to safe value but still sufficient to permit the operation of earth fault protection system. In practice, that value of R is selected that limits the earth fault current to 2 times the normal full load current of the earthed generator or transformer.

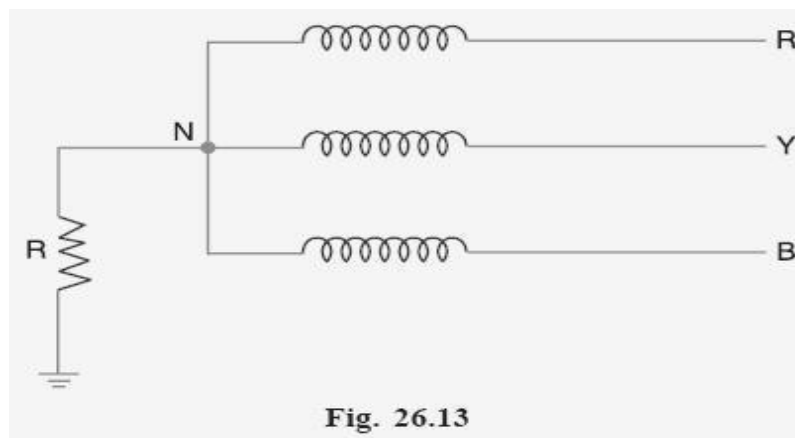

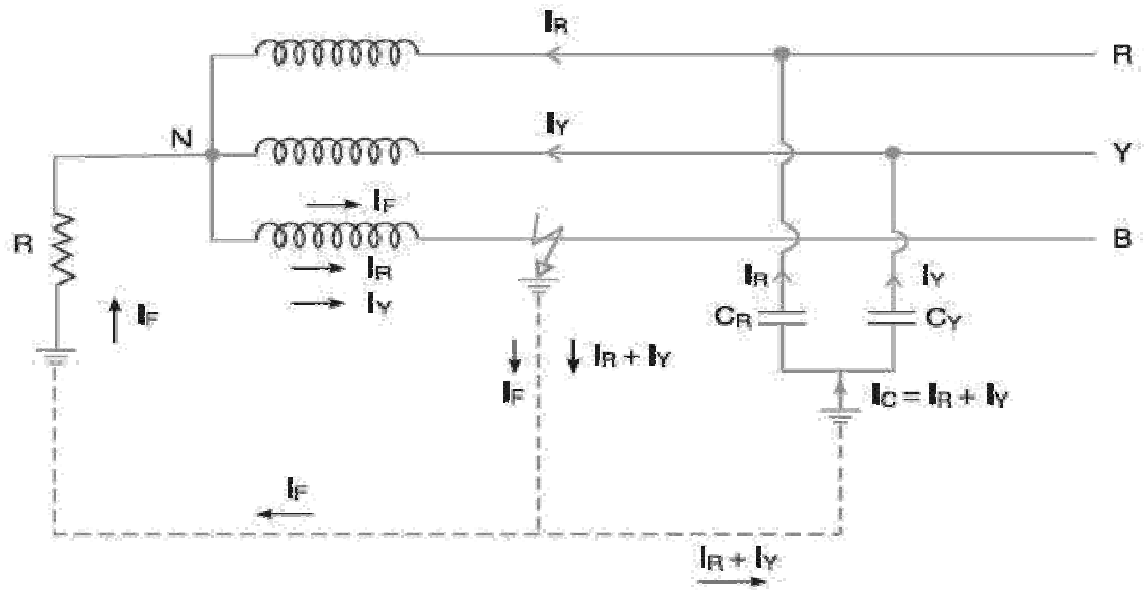

Fig. 26.14

The following are the advantages of resistance earthing:

By adjusting the value of R , the arcing grounds can be minimised. Suppose earth fault occurs in phase B as shown in Fig. 26.14. The capacitive currents I_R and I_Y flow in the healthy phases R and Y respectively. The fault current I_F lags behind the phase voltage of the faulted phase by a certain angle depending upon the earthing resistance R and the reactance of the system upto the point of fault. The fault current I_F can be resolved into two components viz.

- (a) I_{F1} in phase with the faulty phase voltage.
 - (b) I_{F2} lagging behind the faulty phase voltage by 90° .
1. The lagging component I_{F2} is in phase opposition to the total capacitive current I_C . If the value of earthing resistance R is so adjusted that $I_{F2} = I_C$, the arcing ground is completely eliminated and the operation of the system becomes that of solidly grounded system. However, if R is so adjusted that $I_{F2} < I_C$, the operation of the system becomes that of ungrounded neutral system.
 2. The earth fault current is small due to the presence of earthing resistance. Therefore, interference with communication circuits is reduced.
 3. It improves the stability of the system.

The following are the disadvantages of resistance grounding :

1. Since the system neutral is displaced during earth faults, the equipment has to be insulated for higher voltages.
2. This system is costlier than the solidly grounded system.
3. A large amount of energy is produced in the earthing resistance during earth faults. Some times it becomes difficult to dissipate this energy to atmosphere.

Applications:

It is used on a system operating at voltages between 2.2 kV and 33 kV with power source capacity more than 5000 kVA.

Reactance Grounding:

In this system, a reactance is inserted between the neutral and ground as shown in Fig. 26.15. The purpose of reactance is to limit the earth fault current. By changing the earthing reactance, the earth fault current can be changed to obtain the conditions similar to that of solid grounding.

This method is not used these days because of the following disadvantages:

- In this system, the fault current required to operate the protective device is higher than that of resistance grounding for the same fault conditions.
- High transient voltages appear under fault conditions.

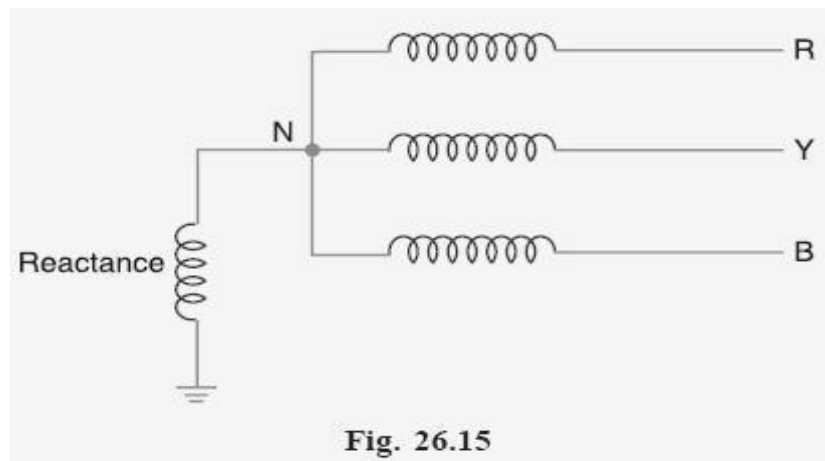

Arc Suppression Coil Grounding (or Resonant Grounding):

We have seen that capacitive currents are responsible for producing arcing grounds. These capacitive currents flow because capacitance exists between each line and earth. If inductance L of appropriate value is connected in parallel with the capacitance of the system, the fault current I_F flowing through L will be in phase opposition to the capacitive current I_C of the system. If L is so adjusted that $I_L = I_C$, then resultant current in the fault will be zero. This condition is known as resonant grounding. When the value of L of arc suppression coil is such that the fault current I_F

exactly balances the capacitive current I_C , it is called resonant grounding.

Circuit details:

An arc suppression coil (also called Peterson coil) is an iron-cored coil connected between the neutral and earth as shown in Fig. 26.16(i). The reactor is provided with tapings to change the inductance of the coil. By adjusting the tapings on the coil, the coil can be tuned with the capacitance of the system i.e. resonant grounding can be achieved.

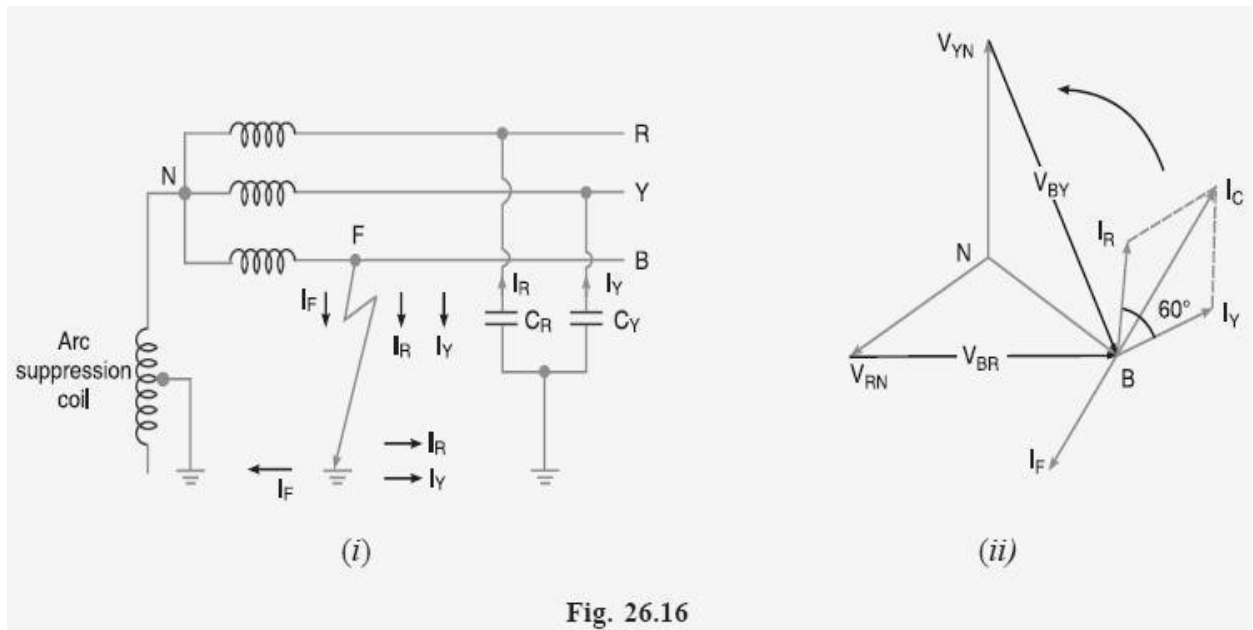

Fig. 26.16

Operation:

Fig. 26.16(i) shows the 3-phase system employing Peterson coil grounding. Suppose line to ground fault occurs in the line B at point F. The fault current I_F and capacitive currents I_R and I_Y will flow as shown in Fig. 26.16 (i). Note that I_F flows through the Peterson coil (or Arc suppression coil) to neutral and back through the fault. The total capacitive current I_C is the phasor sum of I_R and I_Y as shown in phasor diagram in Fig. 26.16(ii). The voltage of the faulty phase is applied across the arc suppression coil. Therefore, fault current I_F lags the faulty phase voltage by 90° . The current I_F is in phase opposition to capacitive current I_C [See Fig. 26.16(ii)]. By adjusting the tapings on the Peterson coil, the resultant current in the fault can be reduced. If inductance of the coil is so adjusted that $I_L = I_C$, then resultant current in the fault will be zero. Value of L for resonant grounding. For resonant grounding, the system behaves as an ungrounded neutral system. Therefore, full line voltage appears across capacitors C_R and C_Y .

$$\therefore I_R = I_Y = \frac{\sqrt{3}V_{ph}}{X_C}$$

$$\therefore I_C = \sqrt{3} I_R = \sqrt{3} \times \frac{\sqrt{3}V_{ph}}{X_C} = \frac{3V_{ph}}{X_C}$$

Here, X_C is the line to ground capacitive reactance.

Fault current,
$$I_F = \frac{V_{ph}}{X_L}$$

Here, X_L is the inductive reactance of the arc suppression coil.

For resonant grounding, $I_L = I_C$

or
$$\frac{V_{ph}}{X_L} = \frac{3V_{ph}}{X_C}$$

or
$$X_L = \frac{X_C}{3}$$

or
$$\omega L = \frac{1}{3\omega C}$$

$$\therefore L = \frac{1}{3\omega^2 C} \quad \dots (i)$$

Exp. (i) gives the value of inductance L of the arc suppression coil for resonant grounding

The Peterson coil grounding has the following advantages:

1. The Peterson coil is completely effective in preventing any damage by an arcing ground.
2. The Peterson coil has the advantages of ungrounded neutral system.

The Peterson coil grounding has the following disadvantages :

1. Due to varying operational conditions, the capacitance of the network changes from time to time. Therefore, inductance L of Peterson coil requires readjustment.
2. The lines should be transposed.

Voltage Transformer Earthing:

In this method of neutral earthing, the primary of a single-phase voltage transformer is connected between the neutral and the earth as shown in Fig. 26.17. A low resistor in series with a relay is connected across the secondary of the voltage transformer. The voltage transformer provides a high reactance in the neutral earthing circuit and operates virtually as an ungrounded neutral system. An earth fault on any phase produces a voltage across the relay. This causes the operation of the protective device.

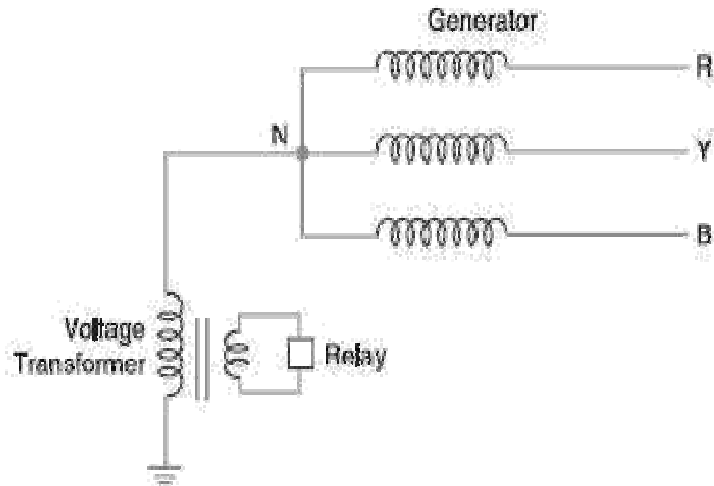

Fig. 26.17

The following are the advantages of voltage transformer earthing :

1. The transient over voltages on the system due to switching and arcing grounds are reduced. It is because voltage transformer provides high reactance to the earth path.
2. This type of earthing has all the advantages of ungrounded neutral system.
3. Arcing grounds are eliminated.

The following are the disadvantages of voltage transformer earthing :

1. When earth fault occurs on any phase, the line voltage appears across line to earth capacitances. The system insulation will be overstressed.
2. The earthed neutral acts as a reflection point for the travelling waves through the machine winding. This may result in high voltage build up.

Applications:

The use of this system of neutral earthing is normally confined to generator equipments which are directly connected to step-up power transformers.

Grounding Transformer:

We sometimes have to create a neutral point on a 3-phase, 3-wire system (e.g. delta connection etc.) to change it into 3-phase, 4-wire system. This can be done by means of a grounding transformer. It is a core type transformer having three limbs built in the same fashion as that of the power transformer. Each limb of the transformer has two identical windings wound differentially (i.e. directions of current in the two windings on each limb are opposite to each other) as shown in

Fig. 26.18. Under normal operating conditions, the total flux in each limb is negligibly small. Therefore, the transformer draws very small magnetizing current

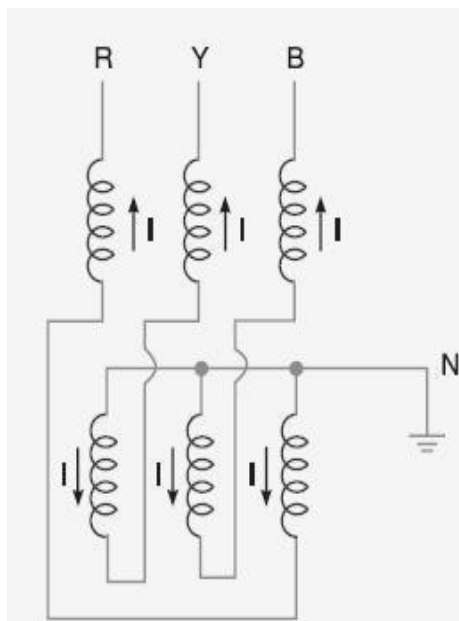

Fig. 26.18

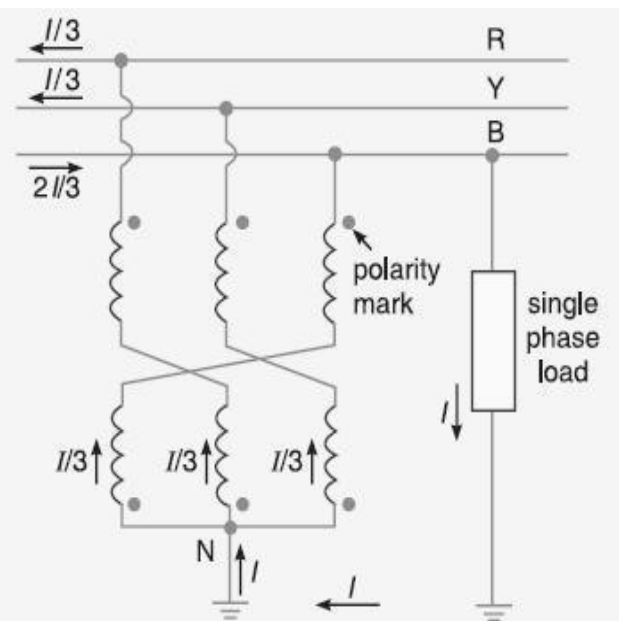

Fig. 26.19

Fig. 26.19 shows the use of grounding transformer to create neutral point N. If we connect a single-phase load between one line and neutral, the load current I divide into three equal currents in each winding. Because the currents are equal, the neutral point stays fixed and the line to neutral voltages remain balanced as they would be on a regular 4-wire system. In practice, the single-phase loads are distributed as evenly as possible between the three phases and neutral so that unbalanced load current I is relatively small.

The impedance of grounding transformer is quite low. Therefore, when line to earth fault occurs, the fault current will be quite high. The magnitude of fault current is limited by inserting a resistance (not shown in the figure) in the neutral circuit. Under normal conditions, only iron losses will be continuously occurring in the grounding transformer. However, in case of fault, the high fault current will also produce copper losses in the transformer. Since the duration of the fault current is generally between 30-60 seconds, the copper losses will occur only for a short interval.

Grounding Practice:

1. Once the grounding is normally provided at each voltage level. Between generation and distribution, there are various voltage levels. It desirable to have ground available at each voltage level.
2. The generation is normally provided with resistance grounding and synchronous capacitors are provided with reactance grounding.
3. Where several generators are connected to a common neutral bus. The bus is connected to ground through a single grounding device. Disconnect switches can be used to ground the desired generators to the neutral bus.
4. Where the several generators are operating in parallel, only one generator neutral is grounded. This is done to avoid the interference of zero sequence components. Normally two grounds are available in a station but only one is used at a time. The other is used when the first generator is out of service.
5. For low voltages up to 600 volts and for high voltages above 33 KV solid grounding is used where as for medium voltage between 3.3 KV and 33 KV resistance or reactance grounding is used.

Module-V

Protection Against Over Voltages

8.1 GENERATION OF OVER VOLTAGE IN POWER SYSTEM

The generation of over voltages in power system can be classified into two categories.

1. External over voltages
2. Internal over voltages

These two categories are discussed briefly.

1. External over Voltages

The over voltages caused due to disturbances in atmosphere is termed as external over voltages. They do not depend on the system operating voltage. The causes for over voltages are

- a) Direct lightning strokes
- b) Over voltages caused by electromagnetic induction due to lightning discharge taking place near the live
- c) Electrostatically induced over voltage due to frictional effect of dust or snow in the atmosphere
- d) Electrostatically induced over voltages due to clouds in the atmosphere
- e) The transmission line is lengthy such that it is subjected to various atmospheric conditions. Due to this over voltages are induced.

2. Internal Over Voltages

Internal over voltages are caused due to changes in the operating conditions of the system. These are further divided into two types.

(i) Transient Overvoltages (Switching Overvoltages)

Transient overvoltages are caused due to transient nature of the system during switching operations or fault conditions. The transient overvoltages are oscillatory with a frequency ranging from few hundred to few KHZ.

Eg:-

- 1) Due to switching of transformer at no load
- 2) Due to fault in one phase, the voltage of healthy phases shoots up

3) Due to closing of circuit breaker contacts to clear a fault which is followed by appearance of restriking voltage. Transient overvoltages are of relatively high frequency

Here we define a term called over-voltage factor. It is the ratio of peak overvoltage to the rated system-frequency phase voltage. This term is also called as amplitude factor.

(ii) Temporary Overvoltages (Steady-State Overvoltages)

These overvoltages are the steady-state over voltages of the system. These over-voltages are of power frequency.

The main cause of steady-state over voltages is due to the disconnection of loads.

The over voltages mentioned above causes damage to the equipment and also insulation of the system, so the system should be protected against these over voltages. The type of protection depends on the factors causing over voltages and also the magnitude, shape and frequency of occurrence of the over voltages.

8.2 PROTECTION AGAINST LIGHTNING OVER VOLTAGES:-

Lightning causes two kinds of over voltages. They are

1. by direct stroke to a line conductor
2. Electromagnetically induced over voltages due to indirect stroke i.e lightning discharge taking place near the line

The over voltages caused due to direct lightning stroke is more severe than due to indirect lightning stroke.

The direct lightning strokes can be approximated to a constant current source since current through the phase conductor due to direct lightning stroke is constant

The transmission lines can be protected against lightning over voltages using lightning arresters or surge diverters.

The surge diverter are connected between line and ground at the substation

These act in parallel with the equipment to be protected, and protects it by

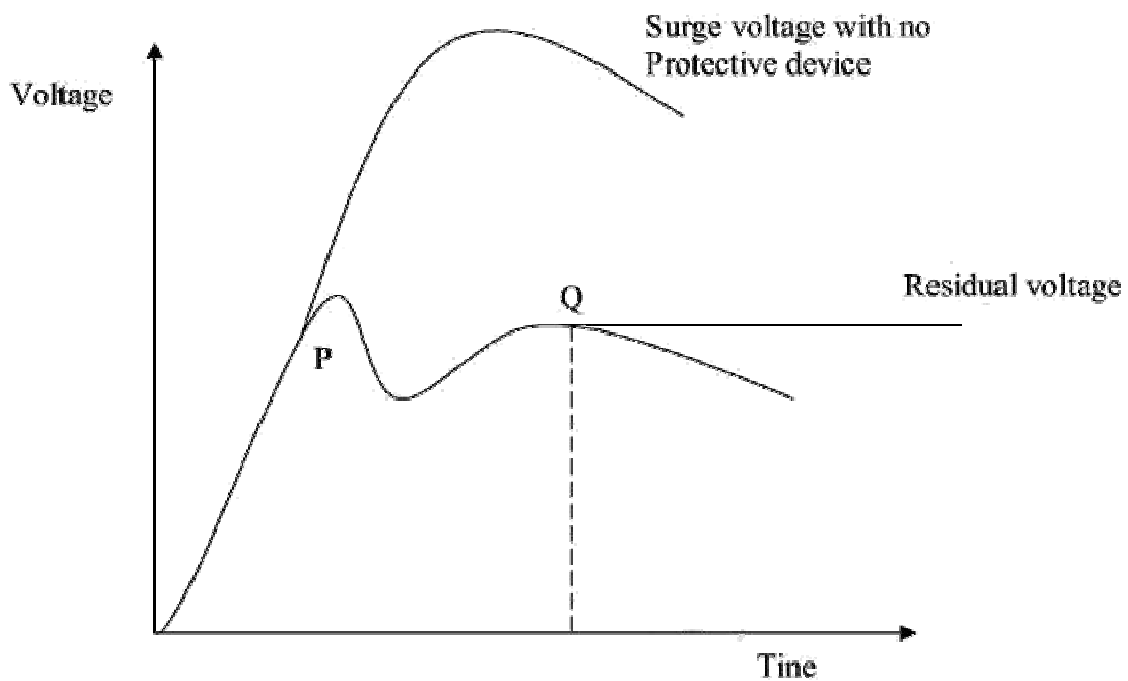

Fig-8.1

When the traveling wave reaches the diverter, the diverter provides a relatively low impedance path to ground for the surge current. This current limits the amplitude of the over voltage across the line known as residual voltage to a value which protects the insulation of equipment

The characteristics of ideal lightning arrester is

- (i) During normal operations it should not draw any current
- (ii) During transients, it should create low-impedance path for the surge currents
- (iii) The discharge current through the diverter should not be so large such that it damages the surge diverter itself

Impulse Ratio

Impulse ratio is defined as the ratio of the breakdown impulse voltage of a wave of specified duration to the breakdown voltage of a power-frequency wave.

Impulse ratio is a function of time duration of the transient wave.

Two types of lightning arresters are discussed below.

8.2.1 Valve Type Lightning Arrester

This type of diverter is also called Non-linear surge diverter. The construction of valve type lightning arrester is shown below.

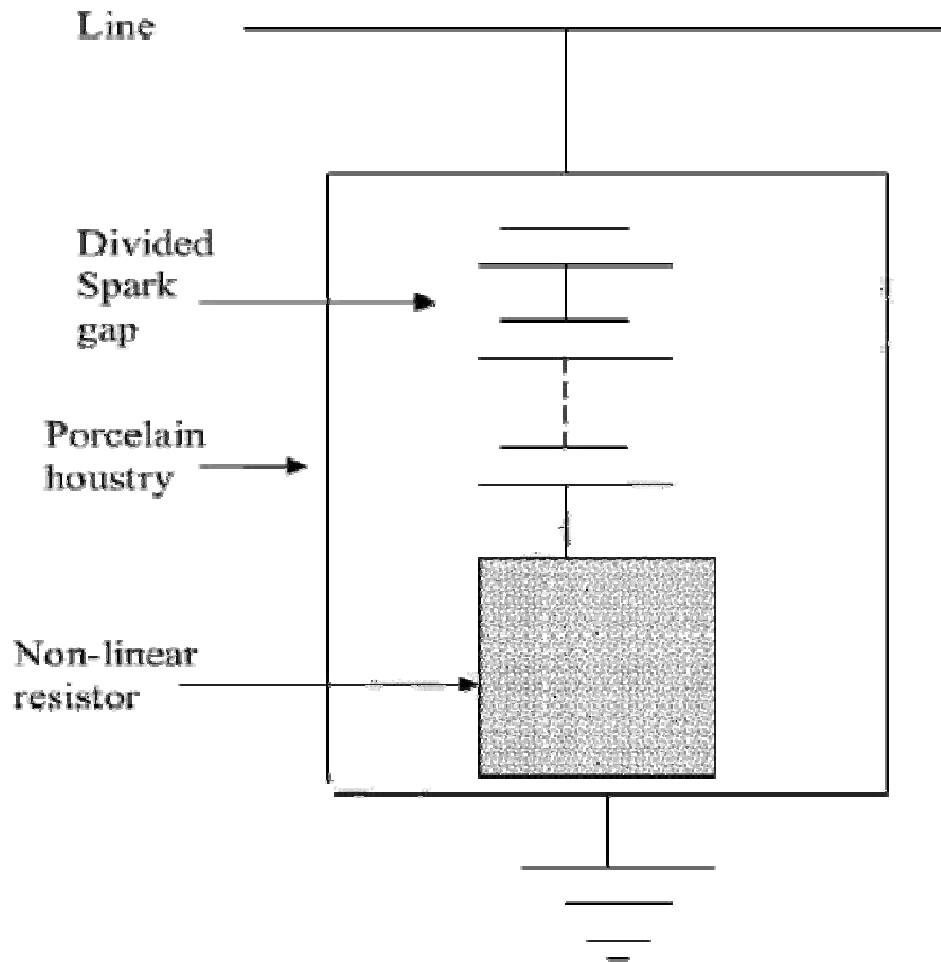

Fig 8.2

It consists of a divided spark gap and a non-linear resistor in series. Divided spark gap consists of number of short gaps in series. These are enclosed in a leaktight porcelain housing.

The divided spark gap consists of several short gaps in series. Each gap has two electrodes and a high resistance is connected across it. The high resistance provides grading of voltage between the various gaps. The resistance connected also raises the interrupting capacity of the divided spark gap.

The function of the divided spark-gap of the diverter is listed below

i) Under normal conditions, it prevents the flow of current through the diverter

ii) It sparks over at a predetermined voltage

iii) It makes the diverter to be capable of interrupting the power frequency follow up current after the surge is discharged to ground

The functions of the non-linear resistors are listed below

i) They provide a high resistance path for the flow of power frequency follow up current

ii) A low impedance path is provided for the flow of surge current

iii) Non-linear resistor provides the dissipating of surge energy

The figure drawn below shown a typical valve type lightning arrester

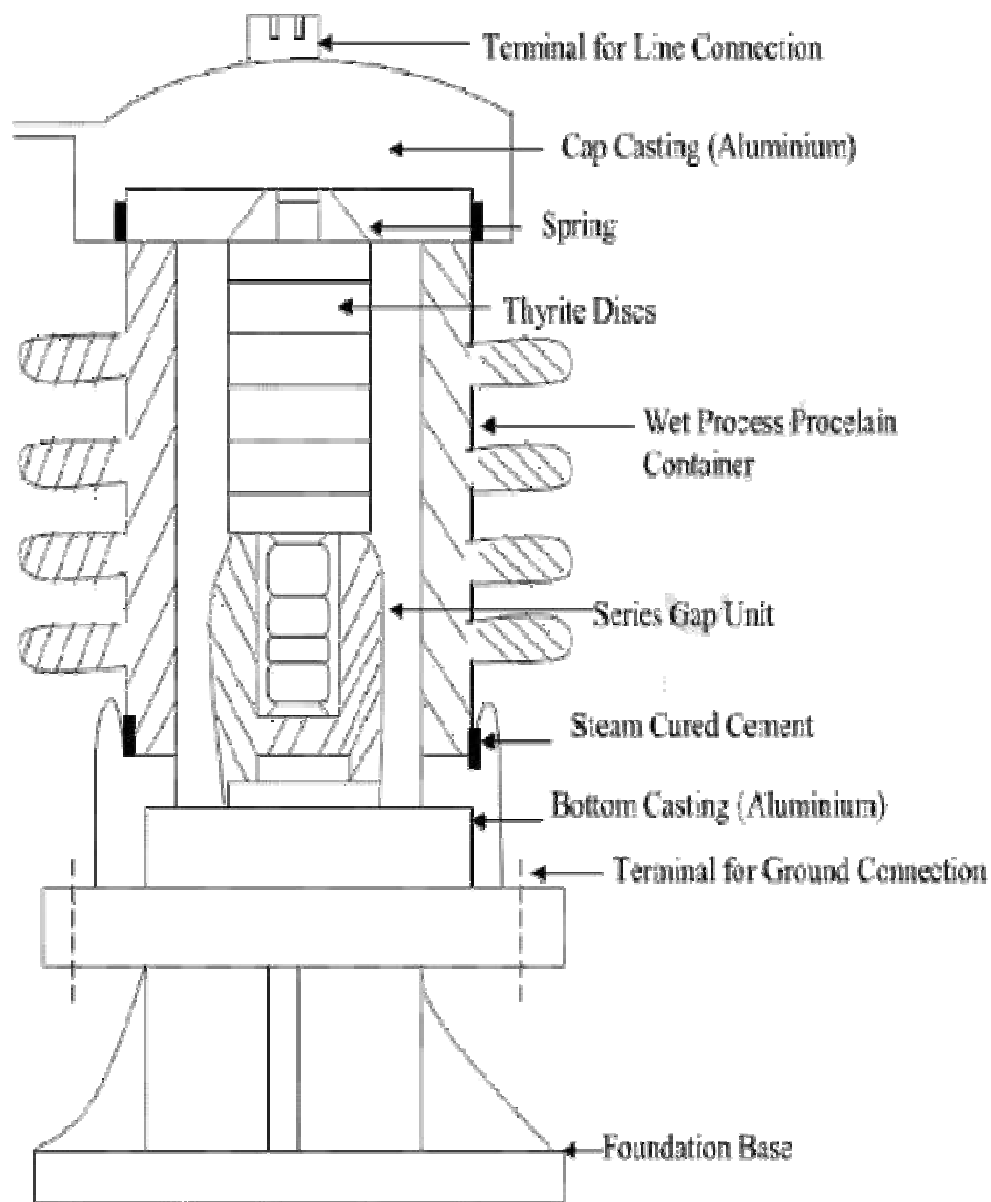

Figure 8.3

Since non-linear resistor changes its resistance inversely proportional to current to maintain voltage constant its ideal characteristics is $RI = \text{constant}$

The non-linear resistor is made up of material named 'thyrite', this type of lightning arrester is also known as 'Thyrite type lightning arrester'

The figure drawn below shown

Volt-ampere characteristics of the non-linear diode

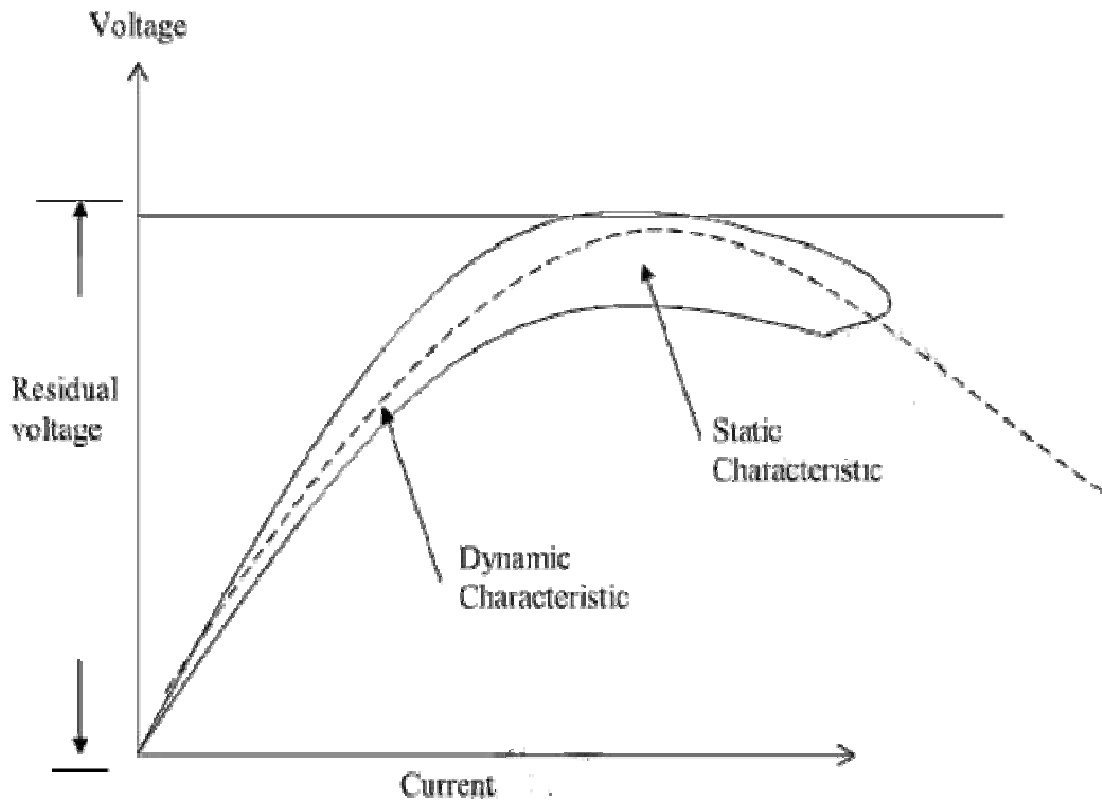

Fig 8.4

The static characteristic is shown by the dotted curve and the dynamic characteristic is shown by the solid curve. The tangent drawn to the dynamic characteristic intersects the voltage axis at a value called "residual voltage"

Hence residual voltage is defined as the "peak value of the voltage between the terminals of the surge diverter at the instant when the surge current discharges through it".

This type of lightning arrester acts as an insulator at normal working conditions. When there are voltage surges, it creates a low impedance path to the surge currents. After the voltage surges has disappeared, again it acts a, an insulator.

Since its function is similar to the valve opening at high surge currents it is called valve type lightning arrester.

8.2.2 Zinc-Oxide Lightning Arrester

The conventional non-linear lightning arresters uses silicon carbide (SiC) as the non-linear resistor. But this material does not exhibit ideal non-linear characteristics and there are some design restrictions.

The Zinc-Oxide lightning arrester uses a series of Zinc-Oxide (ZnO) elements in addition with Oxides such as cobalt Oxide, bismuth with out series spark gaps.

Zinc-Oxide element has high degree of non-linearity. Their volt-ampere characteristics are very close to idea.

The lightning arrester which uses Zinc-Oxide element as non-linear resistor is known as metal Oxide surge arrester (MOA)

The operation of Metal Oxide surge arrester is explained in the following points

- (i) At normal conditions, the peak value of phase to ground voltage is less than the sum of the rated voltage of the discs (elements)
- (ii) When an over-voltage occurs, surge current through it rises and it comes into complete conducting state.
- (iii) When the voltage transient disappear, the current through it decreases following the V-I characteristics.

The characteristics of MOA and conventional non-linear arrester in response to surge $V(t)$ is shown below

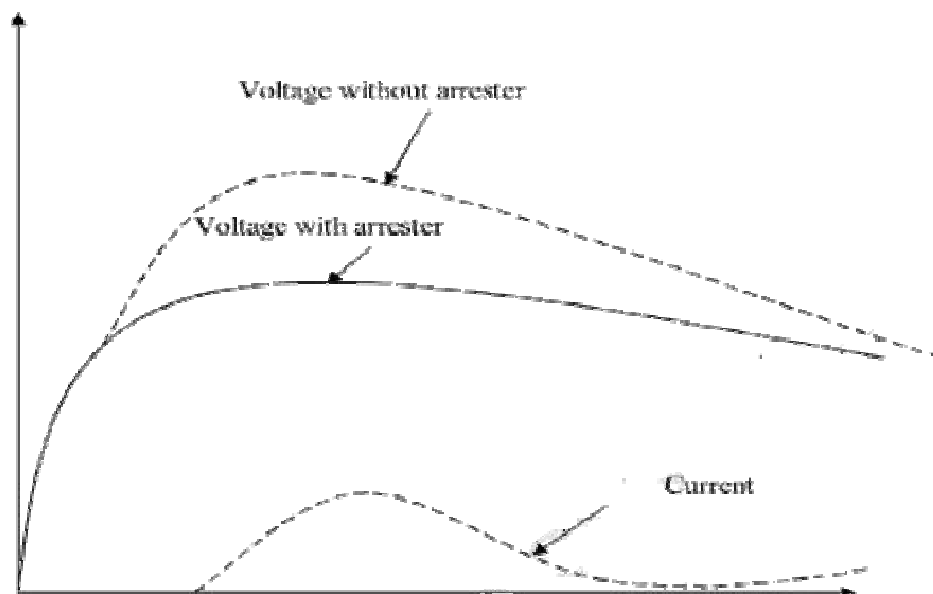

Fig 8.5(a)

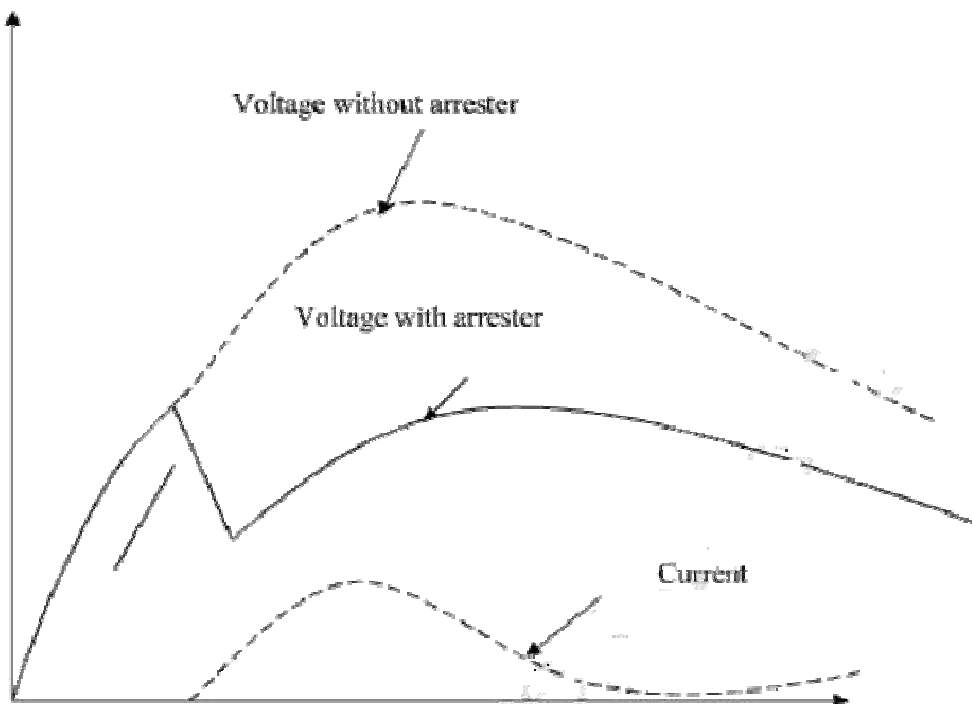

Fig 3.5(b)

Notice that in MOA there is no follow up current

The voltage of MOA expressed as

$$V = 2v(t) - Z_o i \quad (1)$$

Where Z_o is the surge impedance and i is the instantaneous current of the arrester. At the time of spark over in a conventional arrester, the voltage is at its peak value known as spark over voltage. After spark over it follows equation

$$V = 2v(t) - Z_o i$$

From the above discussion we can say that the performance of MOA depends only on discharge voltage but the performance of conventional arrester depends both on spark over voltage and discharge voltage

Since the protection level of MOA is controlled by maximum discharge voltage, the relation between voltage and current can be expressed as

$$V = v(i) \quad (2)$$

By combining equations (1) and (2) the time dependence of V can be calculated. This can be solved graphically as shown in the figure (a) drawn below.

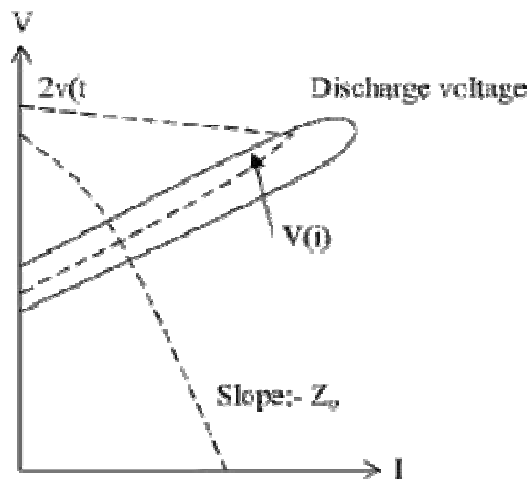

Fig 8.6(a)

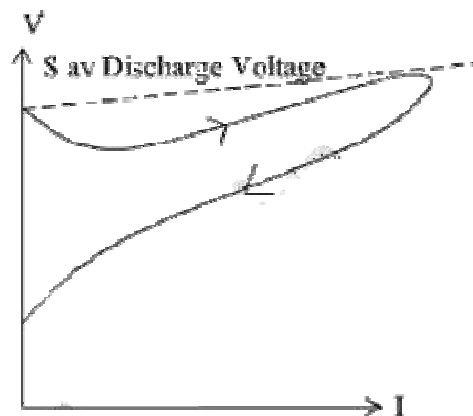

Fig 8.6(b)

Point P_0 in MOA to represent values of V and I corresponding to $v(t)$. It is the intersection point of two curves which is represented by equations (1) and (2). It slides over $v(i)$ curve. The point P moves over the thick line shown in the figure.

The $V-I$ characteristics of conventional arrester is shown in figure (6)

The advantages of Zinc-Oxide surge arrester are as follows

- (i) It is a fully solid-state arrester
- (ii) It is suitable for protection of system up to highest voltages
- (iii) Spark gaps are not required
- (iv) Transients do not occur at spark over
- (v) Power follow-up current is negligible after surge operation
- (vi) Its operating time is less

8.3 INSULATION COORDINATION

Definition:-

Insulation coordination is defined as the correlation of the insulation of electrical equipment and lines with the characteristics of protective devices such that the insulation of the whole power system is protected from excessive over voltages.

It chooses a suitable value of insulation level for a protective system and arranges in such a manner such that the equipment is protected from over voltages.

The insulation level of equipment (eg:- transformer) should be higher than that of protective devices (eg:- surge arrester)

The volt-time curve of protective device (curve A) and equipment to be protected (curve B) is shown below

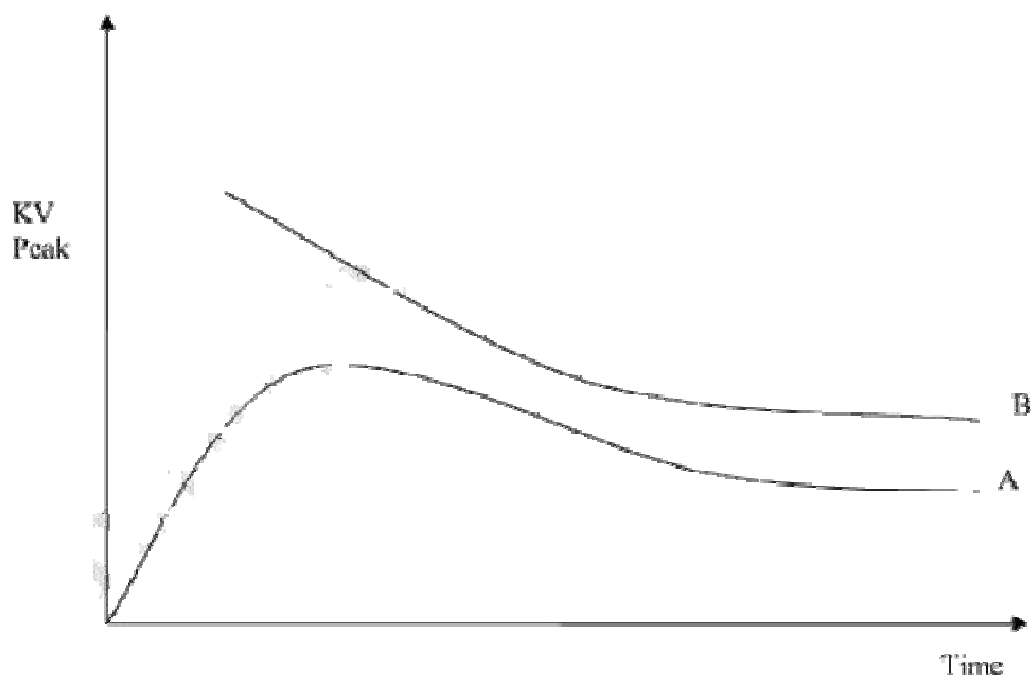

From the above figure we can infer that any equipment whose insulation strength is greater than insulation strength of curve B will be protected by protective device of curve A.

8.3.1 Volt-Time Characteristics

The volt-time characteristics of a particular insulation is a graph of its crest flash over voltage plotted against time of flash over for a series of impulse application of a given wave shape.

A series of impulse voltages of the same wave shape but different peak values is applied to the insulation and the volt-time of the insulation is plotted as shown in the figure drawn below

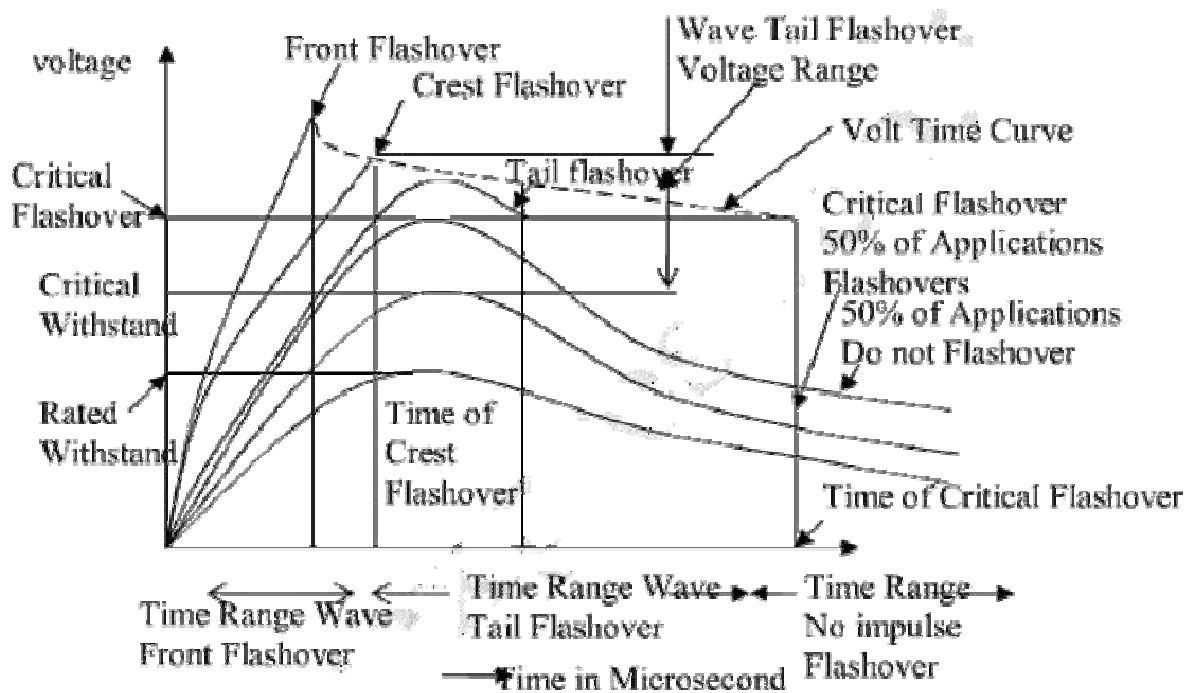

Figure 8.7

If an impulse voltage of given wave shape is applied to a particular insulation and its peak value is adjusted such that it flasher at the front of the wave, then the voltage at point at which front flash over occurs is called front flash over.

If peak value is such that it fails to flash over for 50% of application but flashes over at tail of the wave to other 50% of applications, the peak value of this voltage is called critical flash over.

For an impulse wave, if flash over doesn't take place, then it is called full wave and if flash over takes place then it is called chopped wave.

If the impulse wave is such that its voltage is just below the flash over voltage of the insulation then the voltage called critical with stand voltage.

The peak of impulse wave such that the insulation with stand without disruptive discharge is called rated with stand.

The terminology associated with impulse testing is shown in the figure 8.7

8.3.2 Standard Impulse Test Wave

The standard impulse test wave is obtained from various studies and used for laboratory tests of equipment for proving the withstand capabilities.

The standard impulse test wave for laboratory test wave is shown below

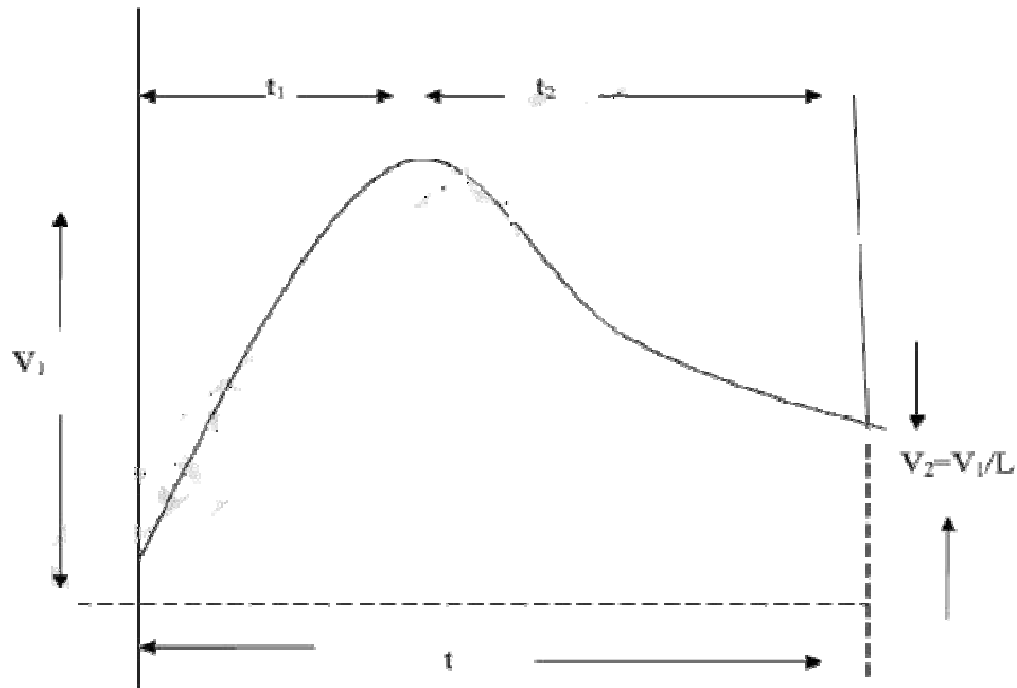

Fig 8.8

In the above figure
For lightning impulse test wave

$$t_1 = 1.2 \mu s$$

$$t_2 = 50 \mu s$$

For switching impulse test wave

$$t_1 = 250 \mu s$$

$$t_2 = 2500 \mu s$$

The peak value of the test wave vary widely

8.3.3 Basic Impulse Insulation Level (BIL)

Definition:-

BIL is the reference value of the peak voltage expressed in KV with standard 1.2/50 μ s lightning impulse wave

The insulation of equipment should with stand the test waves equal to greater than BIL

The BIL for a system to be protected is selected such that the it is protected by suitable lightning protective device.

8.3.4 Impulse Ratio

Impulse ratio for the cause of tature of insulation or flash over is defined as the ratio of 'peak value impulse voltage' to the peak value of power frequency voltage wave to cause the failure of insulation or flash over

$$\text{impuseratio} = \frac{\text{Peakvalueofimpulsevoltage}}{\text{peakvalueofpowerfrequencyvoltagewavetocausetheflashoverorfaihurzofinsulation}}$$